

**WAFER-TYPE NON-RETURN VALVES
 RD40
 (1/2" to 4" – DN 15 to DN 100)**

DESCRIPTION

The ADCA RD40 all stainless steel disc check valves have a compact design and are specially designed for use with steam and hot condensate.

MAIN FEATURES

Low pressure drop.
 Simple and compact design.
 Overall lengths according to DIN EN 558-1 (DIN 3202 part 3, series K4).

OPTIONS: Various soft sealing options:
 EPDM (E), NBR (N), FPM (V), PTFE (T).
 Inconel springs.

USE: Saturated steam, water and other gases and liquids compatible with the construction.

AVAILABLE MODELS: RD40 – stainless steel.

SIZES: 1/2" to 4"; DN 15 to DN 100.

CONNECTIONS: Sandwiched between flanges as per EN 1092 or ASME.

INSTALLATION: Horizontal or vertical installation.
 See IMI – Installation and maintenance instructions.

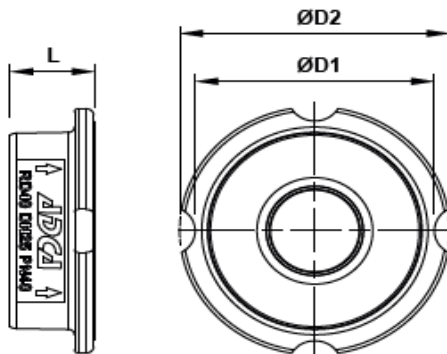

DIMENSIONS				
SIZE	ØD1	ØD2	L	WEIGHT (kg)
1/2" – DN 15	43	50	16	0,2
3/4" – DN 20	53	60	19	0,2
1" – DN 25	62	70	22	0,3
1 1/4" – DN 32	75	81	28	0,5
1 1/2" – DN 40	86	91	32	0,7
2" – DN 50	96	105	40	1,3
2 1/2" – DN 65	115	125	46	1,7
3" – DN 80	133	147	50	2,5
4" – DN 100	154	167	60	3,5

CE MARKING – GROUP 2 (PED – European Directive)	
PN 40	Category
1/2" to 1 1/4" – DN 15 to 32	SEP
1 1/2" to 4" – DN 40 to 100	1 (CE marked)

BODY LIMITING CONDITIONS	
WAFER PN 40 *	
ALLOWABLE PRESSURE	RELATED TEMPERATURE
40 bar	100 °C
33,7 bar	200 °C
31,8 bar	250 °C
29,7 bar	300 °C

* According to EN 1092.
 Minimum operating temperature: - 10 °C.

RECOMMENDED LIMITS OF OPERATION WITH SOFT SEALS			
EPDM (E)	NBR (N)	FPM (V)	PTFE (T)
130 °C	95 °C	180 °C	180 °C

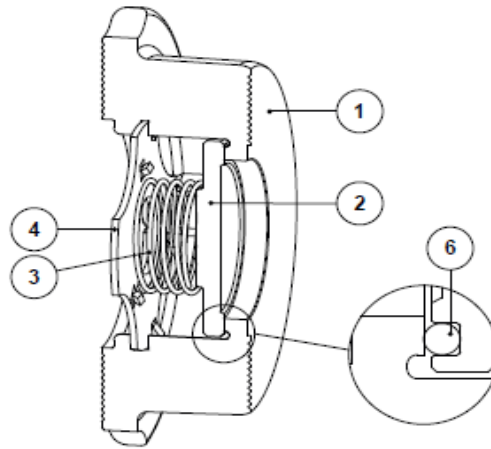

MATERIALS

POS. N°	DESIGNATION	MATERIAL
1	Body	A351 CF8M / 1.4408
2	* Disc	AISI 316 / 1.4401
3	* Spring	AISI 302 / 1.4300
4	Star	AISI 316 / 1.4401
6	* Soft seal	EPDM; NBR; FPM; PTFE

* Available spare parts.

MINIMUM OPENING PRESSURES WITH STANDARD SPRING (mbar)

SIZE	D.P. ↑	D.P. →	D.P. ↓	D.P. * ↑
1/2" – DN 15	25	23	21	2
3/4" – DN 20	25	23	21	2
1" – DN 25	25	23	21	2
1 1/4" – DN 32	27	24	21	3
1 1/2" – DN 40	28	25	21	4
2" – DN 50	29	25	21	4
2 1/2" – DN 65	30	26	21	5
3" – DN 80	31	26	21	5
4" – DN 100	33	27	21	6

→ : Flow direction.

* Vertical installation without springs (bottom to top).

PRESSURE DROP, HORIZONTAL FLOW, STANDARD SPRING (WATER AT 20°)

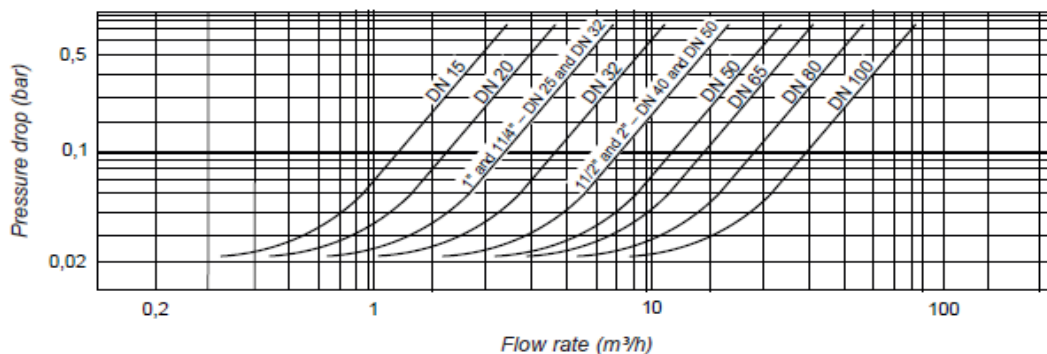

To determine the pressure drop of other mediums the equivalent water flow volume has to be calculated: $V_w = \sqrt{\frac{Q}{1000}} \times V$

V_w = Equivalent water flow volume in m³/h; Q = Density in kg/m³; V = Flow volume in m³/h.