

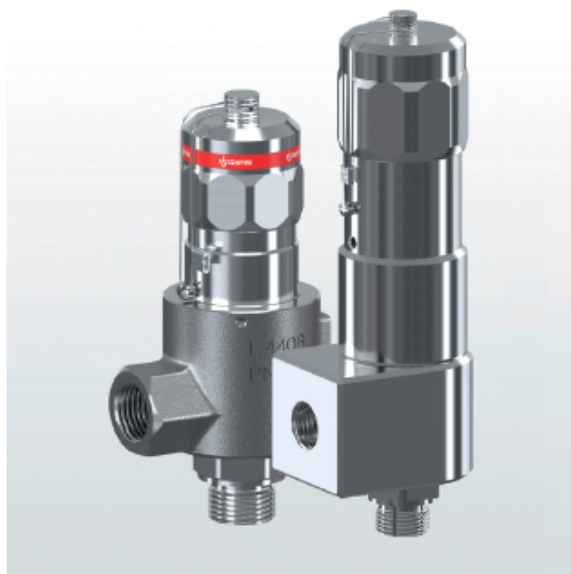



→ **Series 493**

493

Overflow and pressure control valves made of stainless steel, in angle type or with rotatable angle housing, with threaded connections or high-pressure connections



■ **SUITABLE FOR**

Liquids	neutral and non-neutral	
Air, gases and vapours	neutral and non-neutral	
Steam		

■ **EXAMPLES OF USE**

For the protection of:

- Overload protection of pumps in closed circuits for neutral/non-neutral, non-sticking liquids

For control in:

- Pressure systems for neutral/non-neutral gases and vapours and – depending on the seal – also for steam

- Pressure systems for technical gases such as hydrogen
- test rig construction
- mechanical engineering and process equipment construction
- shipbuilding industry and marine equipment
- secondary areas in the food-, beverage-, pharmaceutical- and cosmetics-industries

■ **APPROVALS**

European Pressure Equipment Directive	
Requirements	DGR 2014/68/EU
Classification society	DNV

■ **MATERIAL**



■ **SPECIFICATION**



1/4" – 1"



– 196°C to + 200°C
depending on version



50 – 1000 bar
depending on version

■ **MATERIALS**

Component	Material	DIN EN	ASME
Inlet body	Stainless steel	1.4404	316 L
Outlet body	Stainless steel	1.4404/ 1.4408	316 L / CF8M
Internal parts	Stainless steel	1.4404	316 L
Spring	Spring steel	51Cr V4	

Series 493 ■ VALVE VERSION

t (BI)	gastight version of spring housing	for neutral and non-neutral media without counter pressure. The environment is protected from being affected by the medium
k (BIII)	pressure compensated piston	for neutral and non-neutral an particularly for flammable, toxic and environmentally hazardous media and/or counter pressure up to 500 bar. Spring, moving parts and the environment are protected from being affected by the medium. The piston design allows for a temperature range of -10°C to 150°C.

Valves can be delivered unset within a pressure range or set and sealed at the factory.

■ MEDIUM

GF	gaseous and liquid	Air, vapours, gases, liquids and - depending on safety valve version and seal - also for steam
----	--------------------	--

■ TYPE OF LIFTING MECHANISM

A	externally adjustable
---	-----------------------

■ AVAILABLE NOMINAL DIAMETERS AND CONNECTION SIZES

Nominal diameter DN		BI								BIII						
Inlet		1/4" (8)	3/8" (10)	1/2" (15)	3/4" (20)	ct 3/8"	ct 9/16"	ct 3/4"	ct 1"	1/4" (8)	3/8" (10)	1/2" (15)	3/4" (20)	ct 9/16"	ct 3/4"	ct 1"
Outlet	1/2" (15)	■	■	■	■	■	■	■	■	■	■	■	■	■	■	■
	3/4" (20)	■	■	■	■	■	■	■	■							
	1" (25)	■	■	■	■	■	■	■	■							
	ct 3/8"	■	■	■	■	■	■	■	■	■	■	■	■	■	■	■
	ct 9/16"	■	■	■	■	■	■	■	■	■	■	■	■	■	■	■
	ct 3/4"	■	■	■	■	■	■	■	■							
	ct 1"	■	■	■	■	■	■	■	■							

■ TYPE OF CONNECTION INLET / OUTLET THREADED CONNECTIONS

m / f	50 – 630 bar	Male thread BSP-P / Female thread BSP-P	DIN EN ISO 228-1 / DIN EN ISO 228-1
NPT-m/NPT-f	50 – 1000 bar	Male thread NPT / Female thread NPT	ANSI B1.20.1 / ANSI B1.20.1
ct/f	50 – 1000 bar	cone & thread / Female thread BSP-P	Goetze ct / DIN EN ISO 228-1
ct/ NPT-f	50 – 1000 bar	cone & thread / Female thread BSP-P	Goetze ct/ANSI B1.20.1

Special connections for high pressure possible.

■ SEALS

MD / PEEK	Metal-to-metal sealing / Polyetheretherketone	Flat seal 50 – 1000 bar	-60°C to +180°C
MD / PI	Metal-to-metal sealing/ polyimide	Flat seal 50 – 1000 bar	-196°C to +200°C

NOMINAL DIAMETERS, CONNECTIONS, INSTALLATION DIMENSIONS

Series 493: Connection, installation dimensions, ranges of adjustment

Nominal diameter		DN	8 ¹	10	
Connection DIN EN ISO 228	G		1/4" (8) to 3/4" (20)	1/4" (8) to 3/4" (20)	
Connection Cone & Thread	G		CT 3/8" to CT 1"	CT 9/16" to CT 1"	
Outlet DIN EN ISO 228	G1'		1/2" (15) to 1" (25)	1/2" (15) to 1" (25)	1/2" (15)
Outlet ANSI B1.20.1	G1'		1/2" (15) to 1" (25)	1/2" (15) to 1" (25)	1/2" (15)
Outlet Cone & Thread	G1'		CT 9/16" to CT 1"	CT 9/16" to CT 1"	CT 3/8" to 9/16"
Design			B I	B I	B III
Installation dimensions in mm*	H		172	172	226
	H1 max		43	43	43
	h		12/12/14/16		12/12/14/16
	L max		43	43	74
	SW		27		27
	do		4,5		6
Weight	kg		1,4	1,4	2,9
Set pressure	bar		50-500	50-500	50-1000
Counter pressure	bar		-	-	0-500
Range of adjustment	bar		50 - 400	50 - 200	50 - 350
			100 - 500	150 - 500	200 - 1000

¹Compressed air quality min. according to ISO8573-1:2010[4:1:1]
* Information on the illustrated variant: Threaded connection

MAIN DIMENSIONS, INSTALLATION DIMENSIONS

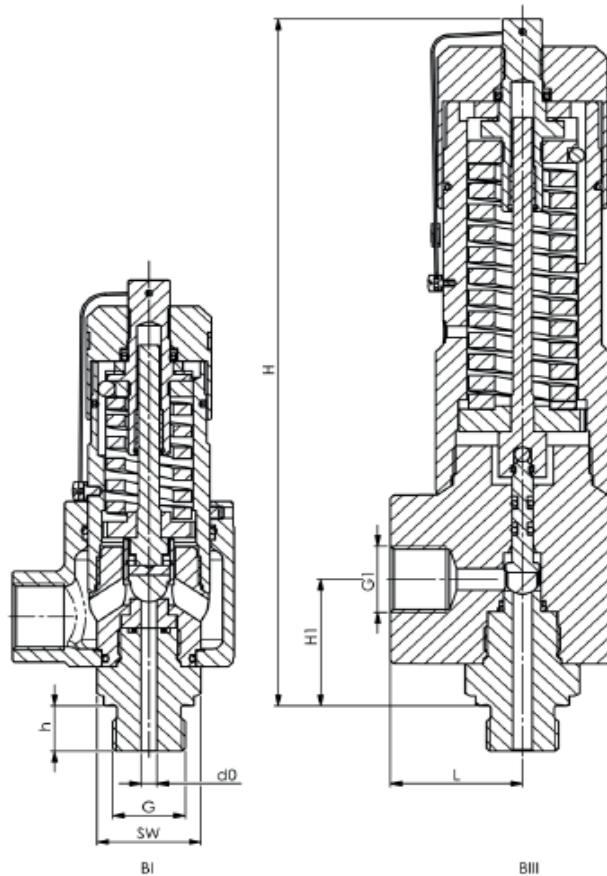

Series 493 ■ INDIVIDUAL SELECTION / VALVE CONFIGURATION

Series	Valve version	Medium	Lifting device	Nominal diameter DN	Connection type		Connection size		Seal	Options	Set pressure	Quantity
					Inlet	Outlet	Inlet	Outlet				
493	<i>t</i>	GF	<i>A</i>	<i>8</i>	<i>ct</i>	<i>f</i>	<i>3/8</i>	<i>20</i>	<i>PEEK</i>		<i>200</i>	<i>1</i>
493	<i>k</i>	GF	<i>A</i>	<i>10</i>	<i>m</i>	<i>f</i>	<i>20</i>	<i>15</i>	<i>PEEK</i>		<i>100 - 300</i>	<i>1</i>
493												
493												

■ OPTIONS

P01	Oil- and grease-free production	<input type="checkbox"/>	<input type="checkbox"/>
		<input type="checkbox"/>	<input type="checkbox"/>

■ CERTIFICATES / APPROVALS

C01	Factory certificate acc. DIN EN 10204 2.2 (WKZ 2.2)	<input type="checkbox"/>	C06	ATEX evaluation acc. to 2014/34/EU	<input type="checkbox"/>
C02-1	Test certificate acc. DIN EN 10204 3.1 (WPZ 3.1) for non TÜV-CE valves marking of individual serial number is required	<input type="checkbox"/>	C10	Certificate of oil- and grease free production	<input type="checkbox"/>
C03	Material test certificate acc. DIN EN 10204 3.1 (MPZ 3.1) (pressure retaining part)	<input type="checkbox"/>			<input type="checkbox"/>
C05	Sealing material Manufacturer certification (FDA, USP 3, 3-A,...), Please indicate description of certificate:	<input type="checkbox"/>			<input type="checkbox"/>

■ CAPACITY TABLE

Series 493: Blowing-off rates at 10% above set pressure							
	Nominal diameter DN	8			10		
		I	II	III	I	II	III
	Set pressure bar						
Air I Nm ³ /h	50	36	27	0,3	54	40	0,4
	60	43	32	0,3	64	48	0,5
	80	58	43	0,4	86	64	0,5
Steam II kg/h	100	72	54	0,4	107	80	0,6
	120	86	64	0,5	128	95	0,7
	140	101	75	0,5	149	111	0,7
Water III m ³ /h	160	115	86	0,5	170	127	0,8
	180	129	96	0,6	191	143	0,8
	200	143	107	0,6	213	159	0,9
	220	158	118	0,6	234	174	0,9
	240	172	128	0,7	255	190	0,9
	260	186	139	0,7	276	206	1,0
	280	201	150	0,7	297	222	1,0
	300	215	160	0,7	318	237	1,0
	320	229	171	0,8	340	253	1,1
	340	243	182	0,8	361	269	1,1
	360	258	192	0,8	382	285	1,1
	380	272	203	0,8	403	301	1,2
	400	286	214	0,8	424	316	1,2
	420	301	224	0,9	445	331	1,2
	440	315	234	0,9	466	347	1,3
	460	329	245	0,9	488	363	1,3
	480	343	256	0,9	509	379	1,3
	500	358	266	0,9	530	394	1,4
	520				551	410	1,4
	540				572	426	1,4
560				593	442	1,4	
580				615	457	1,5	
600				636	473	1,5	
650				689	513	1,5	
700				742	553	1,6	
750				794	592	1,7	
800				847	631	1,7	
850				900	671	1,8	
900				953	710	1,8	
950				1006	750	1,9	
1000				1059	789	1,9	