

→ Series 652

652

Safety valves made of gunmetal, angle-type with threaded connections

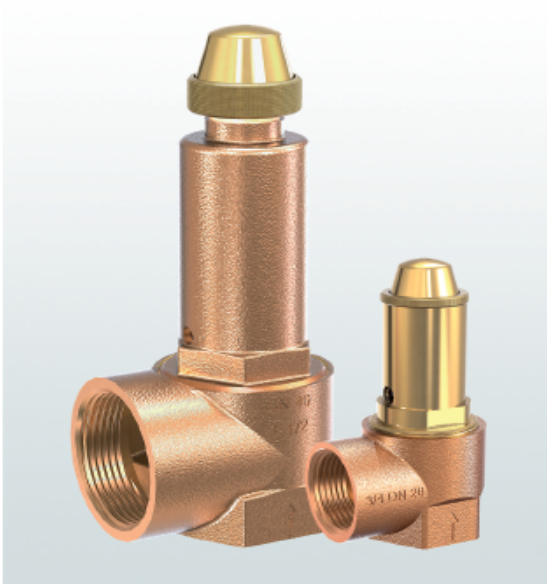

■ SUITABLE FOR

Liquids	neutral	
Air, gases and vapours	neutral	
Steam		

■ EXAMPLES OF USE

For the protection of:

- pressure tanks and systems for water and neutral liquids
- pressure tanks and systems for air, neutral gases and vapours
- steam boiler Cat.I < 10 liter up to 3 bar

Please observe plant-specific regulations and use of appropriate valve version and sealing material.

- pump protection
- pressure booster plants water-/air-side
- cooling-/chilling-systems
- mini steam generators

Safety valves are set and sealed at the factory.

■ APPROVALS

TÜV-Type test approval 293, 312	F, D/G
EU type examination	L, S/G
TR ZU 032/2013 - TR ZU 010/2011	F (L), D/G (S/G)
Requirements	
AD 2000 Data sheet A2 TRD 421 DIN EN ISO 4126-1	PED 2014/68/EU KGS AA 319
Classification society	
DNV Lloyd's Register EMEA American Bureau of Shipping Bureau Veritas Russian Maritime Register of Shipping	DNV LR EMEA ABS BV RS



■ MATERIAL



■ SPECIFICATION



1/2" – 2"



– 50°C to + 200°C
depending on version



1,0 – 16 bar

■ MATERIALS

Component	Material	DIN EN	ASME
Inlet body	Gunmetal	CC499K	CC499K
Outlet body	Gunmetal	CC499K	CC499K
Internal parts	Brass	CW617N	CW617N
Spring	Spring steel with anti-rust protection	1.1200	ASTM A228

Series 652 ■ VALVE VERSION

s	non-gastight version of spring housing	for neutral, gaseous media without counter pressure.
m	with diaphragm	for neutral liquids and liquids in cooling circuits without counter pressure. Spring, moving parts and the environment are protected from being affected by the medium.

■ MEDIUM

F	liquid	The temperature of the medium under atmospheric pressure must not reach boiling point
G	gaseous	Air, vapours, gases and - depending on safety valve version and seal - also for steam

■ TYPE OF LIFTING MECHANISM

K	Standard with twist-type lifting mechanism
---	--

■ AVAILABLE NOMINAL DIAMETERS AND CONNECTION SIZES

Nominal diameter DN	15	20	25	32	40	50
Inlet	1/2" (15)	3/4" (20)	1" (25)	1 1/4" (32)	1 1/2" (40)	2" (50)
Outlet	1/2" (15)	■				
	3/4" (20)		■			
	1" (25)			■		
	1 1/4" (32)				■	
	1 1/2" (40)					■
2" (50)						■

■ TYPE OF CONNECTION INLET / OUTLET THREADED CONNECTIONS

f/f	Standard	Female thread BSP-P / Female thread BSP-P	DIN EN ISO 228-1 / DIN EN ISO 228-1
-----	----------	---	-------------------------------------

■ SEALS

NBR	Nitrile rubber (Standard)	Elastomere flat seal (up to 30% glycol)	-30°C to +130°C
EPDM	Ethylene propylene diene	Elastomere flat seal (up to 100% Glykol)	-50°C to +150°C
FKM	Fluorocarbon	Elastomere flat seal	-20°C to +200°C

Only for type 652sGK for air, neutral vapours

■ NOMINAL DIAMETERS, CONNECTIONS, INSTALLATION DIMENSIONS

Series 652: Connection, installation dimensions, ranges of adjustment							
Nominal diameter	DN	15	20	25	32	40	50
Connection DIN EN ISO 228	G	1/2" (15)	3/4" (20)	1" (25)	1 1/4" (32)	1 1/2" (40)	2" (50)
Outlet DIN EN ISO 228	G	1/2" (15)	3/4" (20)	1" (25)	1 1/4" (32)	1 1/2" (40)	2" (50)
Installation dimensions in mm	L	26	31	35	40	46	54
	H	70	70	80	100	140	155
	h	17	18	22	25	28	34
	SW	27	32	40	49	56	68
	do	10	13	16	18	22	25
Weight	kg	0,2	0,3	0,5	0,7	1,2	1,6
Range of adjustment	bar	1-16	1-16	1-16	1-16	1-16	1-16

■ MAIN DIMENSIONS, INSTALLATION DIMENSIONS

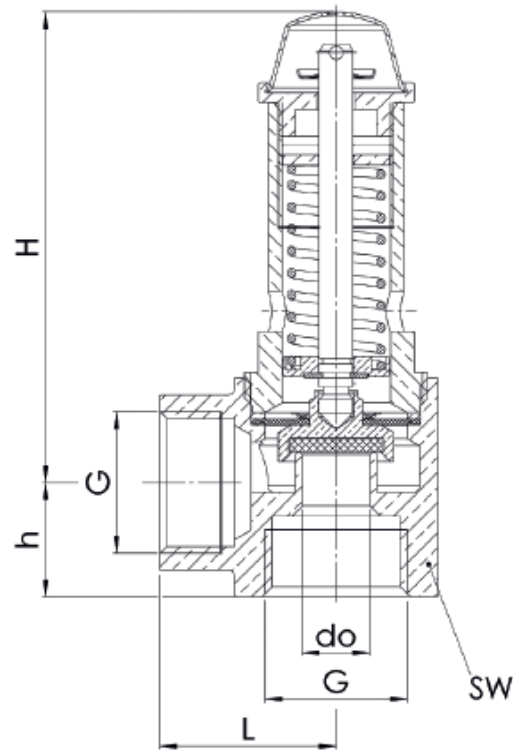

Series 652 ■ INDIVIDUAL SELECTION / VALVE CONFIGURATION

Series	Valve version	Medium	Lifting device	Nominal diameter DN	Connection type		Connection size		Seal	Options	Set pressure	Quantity
					Inlet	Outlet	Inlet	Outlet				
652	<i>m</i>	<i>F</i>	K	15	f	f	15	15	NBR		5,5	2
652	<i>s</i>	<i>G</i>	K	25	f	f	25	25	FKM		3,5	4
652			K		f	f						
652			K		f	f						

■ PROPERTIES

G0X	Especially for gaseous O2 applications by employment of specific materials including oil- and grease free production process	<input type="checkbox"/>	P03	Galvanically nickel-plated finish	<input type="checkbox"/>
P01	Oil- and grease-free production	<input type="checkbox"/>	P04	Chrome-plated finish	<input type="checkbox"/>
P02	Chemically nickel-plated finish	<input type="checkbox"/>			<input type="checkbox"/>

■ CERTIFICATES / APPROVALS

C01	Factory certificate acc. DIN EN 10204 2.2 (WKZ 2.2)	<input type="checkbox"/>	C06	ATEX evaluation acc. to 2014/34/EU	<input type="checkbox"/>
C02	Test certificate acc. DIN EN 10204 3.1 (WPZ 3.1)	<input type="checkbox"/>	C07	SIL evaluation relating to IEC 61508-2	<input type="checkbox"/>
C03	Material test certificate acc. DIN EN 10204 3.1 (MPZ 3.1) (pressure retaining part)	<input type="checkbox"/>	C10	Certificate of oil- and grease free production	<input type="checkbox"/>
C04	TÜV/DEKRA individual inspection acc. EN 10204 3.2 (TÜV/DEKRA-APZ)	<input type="checkbox"/>	C11	Certification of the production process especially for gaseous oxygen applications by employment of specific materials	<input type="checkbox"/>

■ ADMISSIONS / ACCREDITATIONS

AA1	EC Type examination acc. to Directive 2014/68/EU	<input type="checkbox"/>	AK1	Det Norske Veritas (DNV) type approval	<input type="checkbox"/>
AA2	TÜV component test acc. to VdTÜV specification sheet SV 100	<input type="checkbox"/>	AK2	Lloyd's Register (LR) type approval	<input type="checkbox"/>
AA4	EAC - certificate/declaration with passport for the valve and laser marking of the valve	<input type="checkbox"/>	AK3	American Bureau of Shipping (ABS) type approval	<input type="checkbox"/>
		<input type="checkbox"/>	AK4	Bureau Veritas (BV) type approval	<input type="checkbox"/>
		<input type="checkbox"/>	AK5	Russian Maritime Register of Shipping (RMRS) type approval	<input type="checkbox"/>
		<input type="checkbox"/>	AK6	Registro Italiano Navale (RINA) type approval	<input type="checkbox"/>
		<input type="checkbox"/>	AL	Individual inspection by notified body inspector – (body to be indicated):	<input type="checkbox"/>

■ CAPACITY TABLE ACC. TO ISO 4126-1 / AD2000 A2

Series 652: Blowing-off rates at 10% above set pressure																			
Nominal diameter DN		15			20			25			32			40			50		
Set pressure bar		I	II	III	I	II	III	I	II	III	I	II	III	I	II	III	I	II	III
Air I	1	31	25	1,51	53	42	2,55	80	64	3,87	102	81	4,89	152	121	7,31	196	157	9,44
	1,5	40	32	1,85	67	53	3,13	102	81	4,73	128	102	5,99	192	152	8,95	248	197	11,56
	2	48	38	2,14	81	64	3,61	123	97	5,47	155	122	6,92	232	183	10,33	299	236	13,35
Steam II	2,5	56	44	2,39	95	74	4,03	144	113	6,11	182	143	7,73	272	213	11,55	351	275	14,92
	3	64	50	2,62	109	85	4,42	165	129	6,69	208	163	8,47	311	243	12,66	402	314	16,34
	3,5	73	-	2,82	123	-	4,77	186	-	7,23	235	-	9,15	351	-	13,67	454	-	17,65
Water III	4	81	-	3,02	137	-	5,10	207	-	7,73	262	-	9,78	391	-	14,62	505	-	18,87
	4,5	89	-	3,20	150	-	5,41	228	-	8,20	288	-	10,38	431	-	15,50	556	-	20,02
	5	97	-	3,38	164	-	5,71	249	-	8,64	315	-	10,94	471	-	16,34	608	-	21,10
	5,5	105	-	3,54	178	-	5,98	270	-	9,06	342	-	11,47	511	-	17,14	659	-	22,13
	6	114	-	3,70	192	-	6,25	291	-	9,47	368	-	11,98	550	-	17,90	711	-	23,11
	6,5	122	-	3,85	206	-	6,51	312	-	9,85	395	-	12,47	590	-	18,63	762	-	24,06
	7	130	-	3,99	220	-	6,75	333	-	10,23	422	-	12,94	630	-	19,33	814	-	24,97
	7,5	138	-	4,13	234	-	6,99	354	-	10,59	448	-	13,40	670	-	20,01	865	-	25,84
	8	147	-	4,27	248	-	7,22	375	-	10,93	475	-	13,84	710	-	20,67	917	-	26,69
	8,5	155	-	4,40	262	-	7,44	396	-	11,27	502	-	14,26	750	-	21,30	968	-	27,51
	9	163	-	4,53	276	-	7,65	418	-	11,60	528	-	14,68	789	-	21,92	1019	-	28,31
	9,5	171	-	4,65	290	-	7,86	439	-	11,91	555	-	15,08	829	-	22,52	1071	-	29,08
	10	180	-	4,77	303	-	8,07	460	-	12,22	582	-	15,47	869	-	23,11	1122	-	29,84
	11	196	-	2,78	331	-	6,82	502	-	12,82	635	-	14,42	949	-	23,56	1225	-	31,30
	12	212	-	2,91	359	-	7,12	544	-	13,39	688	-	15,06	1028	-	24,61	1328	-	32,69
	13	229	-	3,02	387	-	7,41	586	-	13,94	742	-	15,68	1108	-	25,62	1431	-	34,02
14	245	-	3,14	415	-	7,69	628	-	14,46	795	-	16,27	1188	-	26,58	1534	-	35,31	
15	262	-	3,25	443	-	7,96	670	-	14,97	848	-	16,84	1267	-	27,52	1637	-	36,55	
16	278	-	3,36	470	-	8,22	713	-	15,46	902	-	17,39	1347	-	28,42	1740	-	37,75	