

**BUTT WELD END BALL VALVE  
 FOR HIGH TEMPERATURES**

**KM 9103.X-HT**

DN 10–100 PN 16–160

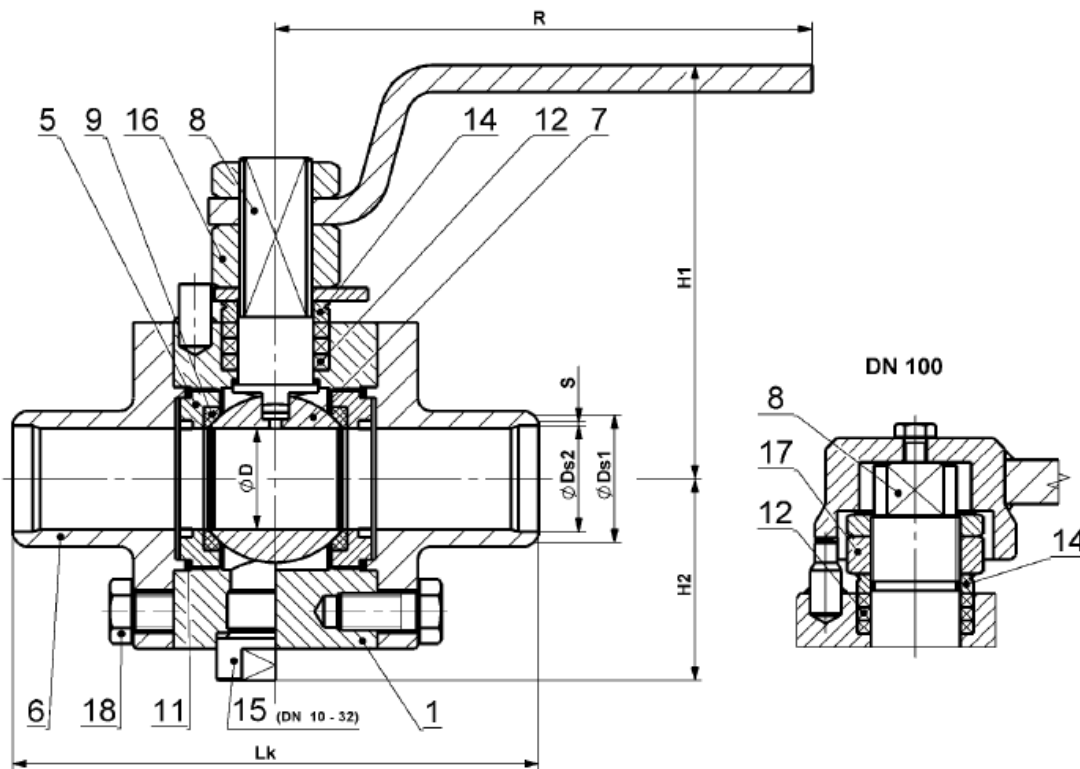

**Materials**

Type KM 9103.X-HT		Material				
		Carbon steel		Alloyed steel	Stainless steel	
Position	Component	X=1 For temperatures from -20 °C to +300 °C	X=5 For temperatures from -46 °C to +400 °C	X=8 <sup>1)</sup> For temperatures from 0 °C to +500 °C	X=3 <sup>1)</sup> For temperatures from -80 °C to +500 °C	X=4 <sup>1)</sup> For temperatures from -80 °C to +500 °C
1	Body	1.0577, S355J2	1.0565, A350 LF2, P355NH	1.5415, 16Mo3	1.4541, A182 F321	1.4571, A182 F316
5	Seat body					
6	Socket					
7	Ball	1.4021, ČSN 17 027	1.4021, ČSN 17 027	1.4923		
8	Stem	1.4021, ČSN 17 027	1.4541, A182 F321			
9	Seat	Carbon+Sb				
11	Gasket	Graphite				
12	Packing	Graphite				
14	Gland cover	1.4021, ČSN 17 027				
15	Screw plug	1.0577, S355J2	1.0565, A350 LF2	1.5415, 16Mo3	1.4541, A182 F321	1.4571, A182 F316
16	Nut	Cl.8, A2-70, A194 Gr. 2H	A2-70, A194 Gr. 7	A2-70 <sup>2)</sup> , A194 Gr. 2H	A2-70 <sup>2)</sup> , A194 Gr. 8	
17	Nut	1.4021, ČSN 17 027		1.4923	1.4021 <sup>2)</sup> , ČSN 17 027 <sup>2)</sup> , 1.4923	
18	Bolt	8.8, A2-70, A193 B7	A2-70, A320 L7	A193 B7, 1.4980	A2-70 <sup>2)</sup> , A193 B8 <sup>2)</sup> , 1.4980	

<sup>1)</sup> = for temperatures above +400 °C for non-oxidizing fluids only

<sup>2)</sup> = material up to +400 °C only.

Other materials upon request (P265GH, 1.4306, 1.4462, 1.7335 etc.).

**Dimensions and weights**

PN 16, 25, 40	DN	øD	øDs1	øDs2	s	Trubka / Pipe	Lk	H1	H2	R	Hm / W
	10	9,5	18	13	-	17,1×2	270	103	37	150	1,8
	15	14	22	16	-	21,3×2,6	270	109	45,5	200	2,5
	20	19	27,5	21,5	-	26,9×2,6	270	122	52,5	250	3,8
	25	25	34	28,5	-	33,7×2,6	270	126	55	250	5
	32	30	43	37	-	42,4×2,6	270	135,5	60	250	7,2
	40	38	49	42,5	1,5	48,3×2,9	270	143	57	250	8,8
	50	47	61	53,5	1,5	60,3×3,2	300	167	72,5	250	16
	65	62	77	69,5	1,5	76,1×3,2	360	159	80	450	23,5
	80	76	90	81,5	1,5	88,9×3,6	390	156	99	454	41
100	95	115	106	1,5	114,3×4	450	192,5	114	540	65	

PN 63	DN	øD	øDs1	øDs2	s	Trubka / Pipe	Lk	H1	H2	R	Hm / W
	10	9,5	18	13	-	17,1×2	270	103	37	150	1,8
	15	14	22	16	-	21,3×2,6	270	109	45,5	200	2,5
	20	19	27,5	21,5	-	26,9×2,6	270	122	52,5	250	3,8
	25	25	34	28,5	-	33,7×2,6	270	126	55	250	5
	32	30	43	37	-	42,4×2,6	270	135,5	60	250	7,2
	40	38	49	42,5	1,5	48,3×2,9	270	143	57	250	8,8
	50	47	61	53,5	1,5	60,3×3,2	300	167	72,5	350	16
	65	62	77	68,5	1,5	76,1×3,6	360	159	80	450	23,5
	80	76	90	80,5	1,5	88,9×4	390	156	99	545	41
100*	95	115	104	1,5	114,3×5	450	192,5	114	540	65	

PN 100	DN	øD	øDs1	øDs2	s	Trubka / Pipe	Lk	H1	H2	R	Hm / W
	10	9,5	18	13	-	17,1×2	270	107	43	200	2,9
	15	14	22	16	-	21,3×2,6	270	109	48	200	3
	20	19	27,5	21,5	-	26,9×2,6	270	119	48,5	250	4,1
	25	25	34	27,5	1,5	33,7×2,9	270	126	57,5	250	6,5
	32	30	43	36	1,5	42,4×3,2	270	137,5	61,5	250	8,2
	40	38	49	41	1,5	48,3×3,6	270				
	50	47	61	51	1,5	60,3×4,5	300	167	72,5	350	16
	65	62	77	66	1,5	76,1×5	360				
	80*	76	90	77,5	1,5	88,9×5,6	390				
100**	95	115	100	1,5	114,3×7	450					

\* = gearbox recommended, \*\* = with gearbox only. Dimensions in [mm], weights in [kg]. Dimensions of welding ends according to the dimensional table or customer requirement. Dimensions for PN 160 upon request.

**Type designation**

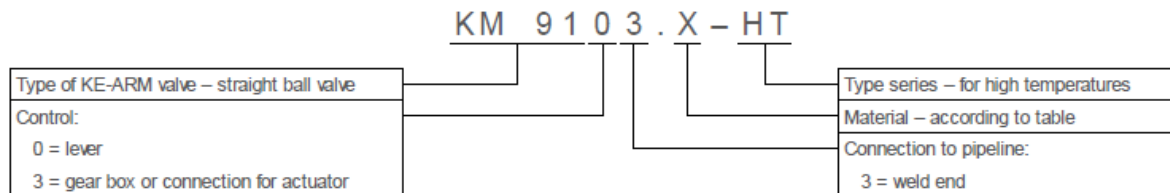

### Application

Isolating valve designed to fully open or close the service fluid flow. It is not designed to be used for throttling or regulating purposes. For temperatures up to +500 °C (for temperatures above +400 °C for non-oxidizing fluids only).

Suitable for:

- water, steam, gas, oil, heat transfer fluids and other liquids and gases without mechanical impurities.

Approved for:

- fluids in groups 1 (hazardous) and 2 according to 2014/68/EU.

### Characteristics

- floating ball,
- full bore,
- anti-static design,
- stem secured against release (anti-blow-out).

### Operation

- hand lever,
- hand wheel with worm gear,
- pneumatic actuator,
- electric actuator.

### Compliance with standards

- EN 1983,
- EN 12516-1,
- EN 17292,
- EN 12982 series 68,
- EN ISO 5211,
- EN 13463-1 (ATEX) – II 1 GD Ex IIC TX, I M1.

### Testing

- EN 12266-1, leakage rate A – zero leakage.

### Optional accessories, adjustments and services

- different end-to-end dimensions or end combinations,
- connection for actuator according to ISO 5211,
- fire-safe design – fire resistance in accordance with EN ISO 10497 (API 607),
- heating jacket – for keeping the fluid liquid,
- lockable handle with a padlock,
- extended stem – e.g. for the reason of insulation of the valve and pipeline,
- design according to TA-Luft or EN 15848-1,
- limit switches,
- documentation according to EN 10204 3.2,
- special adjustments according to customer requests,
- design according to standard NACE MR 0175 or ISO 15156.

### Pressure-temperature graph

