

FIG.118 (ex. ZKS 250)



GATE VALVE zFAG



Body material	Nominal pressure	Nominal diameter	Max. temperature
G forged steel	U 250 bar	DN 50-100	450°C
Q alloy steel	U 250 bar	DN 50-100	580°C













correspond to the pressure equipment directive 2014/68/UE marking CE for DN≥32

FEATURES

- high tightness (leakproofness class - A acc. to EN - 12266 - 1
- compact settlement
- environment friendly
- tests acc. to EN - 12266 - 1

APPLICATION*

* not all of the applications are suitable for all of the executions
 On the website www.zetkama.com.pl is a Chemical Resistance List, which specifies the parameters of work for a given medium.

industries						
	INDUSTRY	SHIPBUILDING INDUSTRY	HEATING	REFRIGERATION AND AIR CONDITIONING	POWER ENGINEERING	
media						
	GLYCOL	INDUSTRIAL WATER	DIATHERMIC OIL	STEAM	COMPRESSED AIR	NEUTRAL FLUIDS

MATERIALS, DIMENSIONS

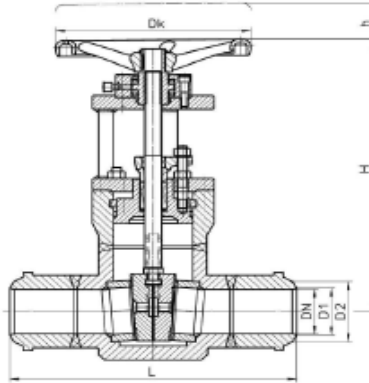

	Body material	G	Q	Q
	Type	01	01	01
	PN	250		
1	Body	P245GH	13CrMo4-5	11CrMo9-10
2	Seat ring	X17CrNi16-2Ni 16-2	Stellite	Stellit
3	Bonnet	P265GH	13CrMo4-5	11CrMo9-10
4	Wedge	X30Cr13	Stellite	Stellit
5	Stem	X30Cr13	X39CrMo17-1	X39CrMo17-1
6	Gasket	graphite		
Max. temperature		450°C	550°C	580°C

DN	50	65	80	100
D1(mm)	45	57,5	84	105
D2(mm)	60	77	108	135
L(mm)	350	425	470	550
Dk (mm)	320	320	320	400
H (mm)	420	490	490	450
h (mm)	60	80	90	110
Weight (kg)	80,0	87,0	120,0	165,0

PRESSURE-TEMPERATURE RATINGS

	PN		100°C	300°C	400°C	450°C	500°C	510°C	520°C	530°C	550°C	580°C
P245GH	250	bar	250	250	216	132	-	-	-	-	-	-
13CrMo4-5			250	250	231	227	193	164	125	120	69	-
11CrMo9-10			250	250	250	250	250	234	190	188	138	62

Other type of valves on request.

TYPE

Figure	Body material	Nominal diameter	Nominal pressure	Type
118	G forged steel P245GH	50-100 mm	U 250 bar	Steel wedge, steel ring 01
118	Q alloy steel 13CrMo4-5	50-100 mm	U 250 bar	Steel wedge- stellited , steel ring 01
118	Q alloy steel 11CrMo9-10	50-100 mm	U 250 bar	Steel wedge- stellited , steel ring 01

ORDERING

Figure	Body material	Nominal diameter	Nominal pressure	Type
118	G forged steel P245GH	50-100 mm	U 250 bar	Steel wedge, steel ring 01

Order example acc. index

118 G 050 U 01

Gate valve, ends welded, form straight

Forged steel P245GH

Nominal diameter (mm)

Nominal pressure PN 250

Steel wedge, steel ring

