

Minimatic

On/Off Control Valves



HIGH QUALITY • COMPETITIVE • COMPACT



Minimatic Control Valves

2-Way On/Off or 3-Way Vent/Drain/Bypass
Compact Competitive Flow Control Valves
DN 15 to DN 50 Screwed or DN 15 to DN 40
Flanged connections.

The Minimatic Control Valve provides
efficient On/Off control for liquids, steam,
air or gases.

Main Features

- Lightweight for ease of handling
- Compact for when space is limited
- Robust design for minimal maintenance
- All valves incorporate our new "Low Fugitive Emission" maintenance free gland seals
- 2 way or 3 way body configurations
- Cast Bronze for pressures up to 16 Bar and 180°C
- Investment cast 316 stainless steel bodies for pressures up to 25 Bar and 180°C
- Pneumatic actuator - spring return
- Stainless steel plug & spindle assemblies for On/Off duties
- PTFE soft seat insert for tight shut-off



Minimatic

On/Off Control Valves



Fig. 71-72 Screwed

Fig. 71 2-Way on/off, Fails closed
 Fig. 72 3-Way diverting. Fails to top seat

- Body material**
- Gunmetal
 - Stainless Steel*
- Maximum working pressure**
- 16 bar g
 - 25 bar g
- Saturated steam**
- 9 bar g
 - 9 bar g
- Maximum temperature**
- 180°C
 - 180°C
- Maximum actuator pressure**
- 4 bar g
 - 4 bar g
- Seating material**
- PTFE
 - PTFE

*Investment cast stainless steel (316) rated at 25 bar g only available in 1/2", 3/4" & 1" sizes

Fig. 71

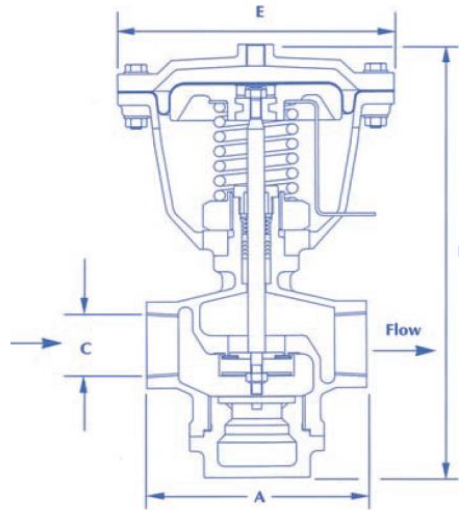
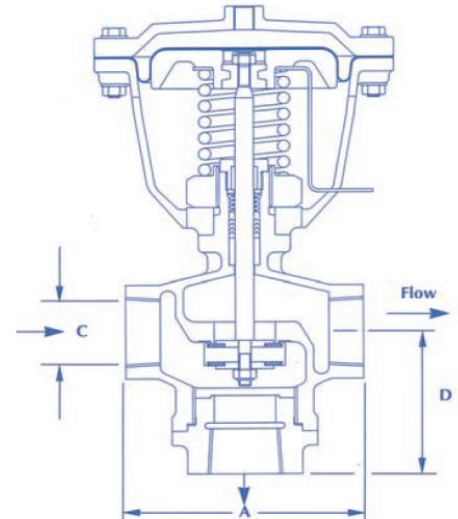

Fig. 72



Size	Kv	Diaphragm Area (sq. cm)	A	B	C BSP Taper	D	Top Cover Dia. E
1/2"	5	56	88	176	1/2"	54	130φ
3/4"	6	56	88	176	3/4"	54	130φ
1"	10	56	104	199	1"	66	130φ
1 1/2"	25	134	155	324	1 1/2"	99	195φ
2"	40	134	178	329	2"	99	195φ

Fig. 77-78 Flanged

Fig. 77 2-Way on/off, Fails closed
 Fig. 78 3-Way diverting. Fails to top seat

- Body material**
- Gunmetal
- Maximum working pressure**
- 16 bar g
- Maximum temperature**
- 180°C
- Saturated steam**
- 9 bar g
- Maximum actuator pressure**
- 4 bar g
- Seating material**
- PTFE

Fig. 77

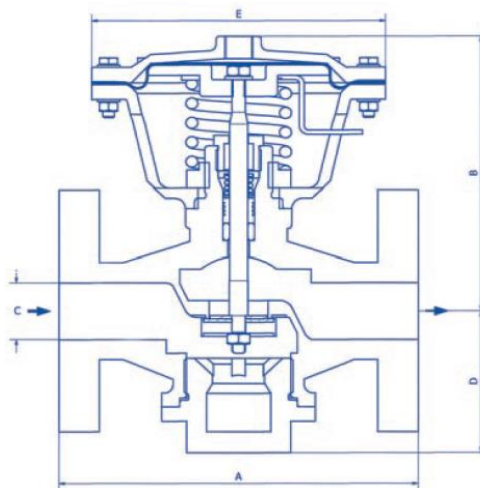
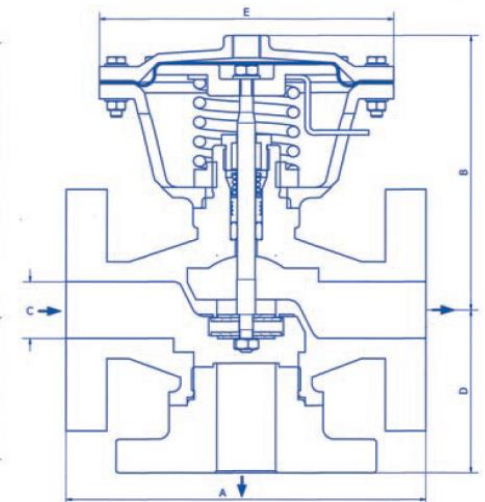

Fig. 78



Size	Kv	Diaphragm Area (sq. cm)	A	B	C	D Fig. 77	D Fig. 78	Top Cover Dia. E
1/2"	5	56	152	126	15	54	70	130
3/4"	6	56	152	126	20	54	70	130
1"	10	56	159	134	25	66	76	130
1 1/2"	25	134	165	226	40	99	89	195