

AIR FILTER REGULATOR P10

DESCRIPTION

The P10 air filter regulators are used to remove both solid and liquid impurities from the air and to regulate the output pressure to the required value for general purpose pneumatic systems. The filter bowl is transparent, allowing easy monitoring of the condensate level.

MAIN FEATURES

- Self relieving.
- Compact combined filter/regulator.
- 5 micron large surface area element.
- Manual and automatic condensate exhaustion are easier when there is no pressure.
- Pressure gauge D.42 x 1/8"
- Mounting bracket.

USE: Pneumatic systems.

AVAILABLE

MODELS: P10 – aluminium and polycarbonate.

SIZE AND

CONNECTION: Female threaded ISO 7 Rp 1/4".

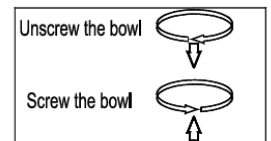
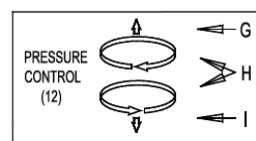
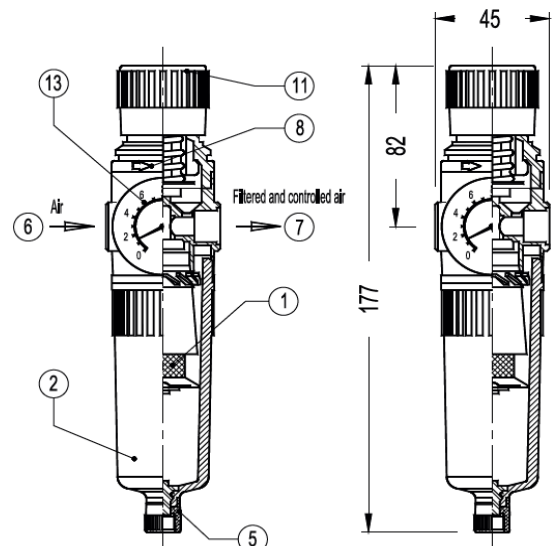

LIMITING CONDITIONS	
Valve model	P10
Maximum upstream pressure	12 bar
Maximum downstream pressure	10 bar
Minimum downstream pressure	0,5 bar
Maximum design temperature	60 °C
Minimum operating temperature	-10 °C

MATERIALS	
POS. N°	DESIGNATION
1	Filtering element
2	Bowl (with bowl guard included)
5	Exhaust ring
6	Air inlet connection
7	Low pressure air outlet
8	Flow indicator arrow
11	Pressure regulating knob
13	Pressure gauge

* Available spare parts.

