

**SANITARY PRESSURE SUSTAINING VALVE
 PS161**

DESCRIPTION

The ADCAPure PS161 is a series of angle design direct acting diaphragm sensing pressure sustaining valves. These regulators, available with spring or dome-loading, are designed for use with clean steam, compressed air, water and other gases or liquids compatible with the construction materials and valve design.

MAIN FEATURES

- Spring or dome-loaded.
- Non-rising adjustment knob.
- Compact design with clamped body.
- Available with low pressure diaphragm.
- FDA / USP Class VI compliant seals.
- Optimized internal designed to provide high flow capacities and minimum droop.
- Completely machined from bar stock material, no castings or forgings are used.

STANDARD SURFACE FINISH

- Internal wetted parts: $\leq 0,51$ micron Ra – SF1.
- External: $\leq 0,76$ micron Ra – SF3.
- Other surface conditions see IS PV20.00 E – Technical information.
- Ultrasonic cleaning.

- OPTIONS:**
- Leakage line connection 1/8" (captured vent).
 - Different soft sealings for liquids and gases.
 - Gauge connection on body.
 - Top cap (adjustment screw with cover).
 - Dome-loaded version.

- USE:**
- Clean steam, compressed air, water and other gases and liquids compatible with the construction.

- AVAILABLE MODELS:**
- PS161.

- SIZES:**
- 1/2" to 2"; DN 15 to 50.

- REGULATING RANGES:**
- 0,8 to 1,5 bar; 1 to 3 bar; 1,5 to 5 bar.

- CONNECTIONS:**
- ASME BPE, DIN and ISO clamp ferrules or tube weld (ETO) ends.
 - Others on request.

- PACKAGING:**
- Assembling and packaging in a clean room certified according to ISO 14644-1.
 - The product is end capped and sealed with recyclable thermo-shrinkable plastic film, to avoid contamination.

- INSTALLATION:**
- Horizontal installation. Horizontal inlet and vertical outlet angle connection. See IMI.

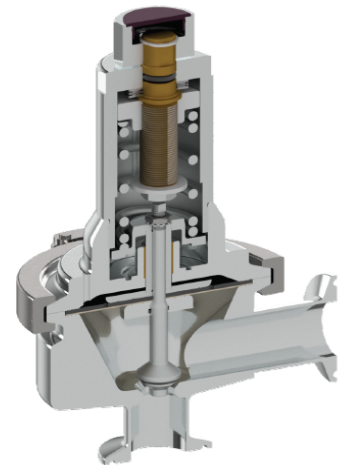

LIMITING CONDITIONS	
Valve model	PS161
Body design conditions	PN 16
Maximum upstream pressure	8 bar
Minimum upstream pressure	0,8 bar
Maximum operating temperature *	180 °C

* With PTFE diaphragm and seals. Consult the manufacturer in case of other elastomer materials.

CE MARKING – GROUP 2 (PED – European Directive)	
PN 16	Category
1/2" to 2" – DN 15 to 50	SEP

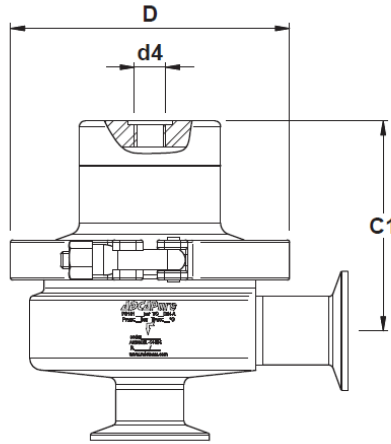
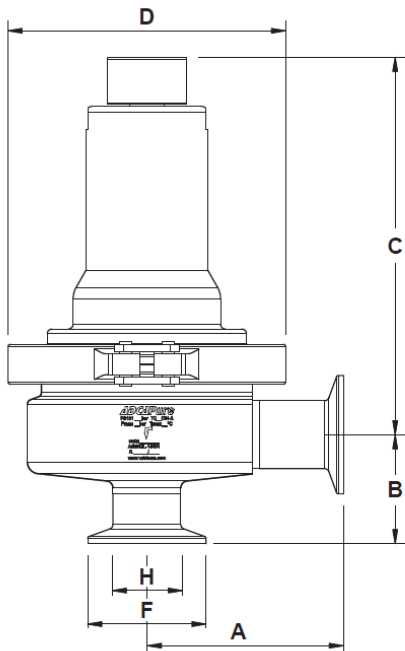

Optional dome-loaded version.

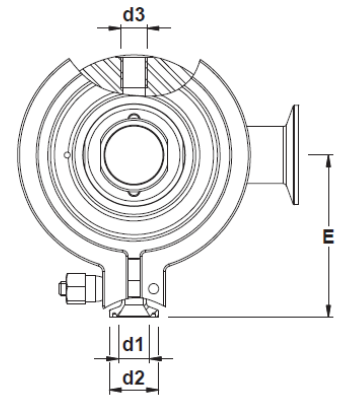

Optional pressure gauge connections.

DIMENSIONS (mm) ASME BPE

SIZE	A	B	C	C1	D	d1	d2	d3 *	d4 *	E	F	H	WGT. (kg)
1/2"	77	53	156	84	119	25	15,75	1/4"	1/4"	83	25	9,4	4,1
3/4"	77	56	160	88	119	25	15,75	1/4"	1/4"	83	25	15,75	4,4
1"	77	52	163	91	119	25	15,75	1/4"	1/4"	83	50,5	22,1	4,6
1 1/2"	85	61	204	124	134	25	15,75	1/4"	1/4"	96	50,5	34,8	8
2"	85	67	207	127	134	25	15,75	1/4"	1/4"	96	64	47,5	8,6

DIMENSIONS (mm) DIN

SIZE	A	B	C	C1	D	d1	d2	d3 *	d4 *	E	F	H	WGT. (kg)
DN 15	77	45	160	88	119	25	15,75	1/4"	1/4"	83	34	16	4,4
DN 20	77	40	158	86	119	25	15,75	1/4"	1/4"	83	34	20	4,3
DN 25	84	47	161	89	119	25	15,75	1/4"	1/4"	83	50,5	26	4,6
DN 32	84	50	163	91	119	25	15,75	1/4"	1/4"	83	50,5	32	4,8
DN 40	93	69	202	122	134	25	15,75	1/4"	1/4"	96	50,5	38	8
DN 50	93	75	206	126	134	25	15,75	1/4"	1/4"	96	64	50	8,6

Remarks: Clamp ferrules according to DIN 32676-A; Tube weld (ETO) according to DIN 11866-A (DIN 11850-2).

DIMENSIONS (mm) ISO

SIZE	A	B	C	C1	D	d1	d2	d3 *	d4 *	E	F	H	WGT. (kg)
DN 15	84	43	159	87	119	25	15,75	1/4"	1/4"	83	50,5	18,1	4,4
DN 20	84	46	162	90	119	25	15,75	1/4"	1/4"	83	50,5	23,7	4,6
DN 25	84	49	164	92	119	25	15,75	1/4"	1/4"	83	50,5	29,7	4,8
DN 32	93	70	202	122	134	25	15,75	1/4"	1/4"	96	64	38,4	8,2
DN 40	93	75	206	126	134	25	15,75	1/4"	1/4"	96	64	44,3	8,8

Remarks: Clamp ferrules according to DIN 32676-B; Tube weld (ETO) according to DIN 11866-B (ISO 1127).

* As standard, connections d3 and d4 are female threaded ISO 7 Rp.

FLOW RATE COEFFICIENTS (m ³ /h)																
	ASME BPE					DIN						ISO				
SIZE	1/2"	3/4"	1"	1 1/2"	2"	DN 15	DN 20	DN 25	DN 32	DN 40	DN 50	DN 15	DN 20	DN 25	DN 32	DN 40
Kvs	1,6	3,2	5,3	13,0	19,8	2,8	3,2	5,3	5,3	13,0	19,8	2,8	5,3	5,3	13,0	13,0

MATERIALS		
POS. N°	DESIGNATION	MATERIAL
1	Valve body	AISI 316L / 1.4404
2	Cover	AISI 316L / 1.4404
3	Intermediate flange	AISI 316L / 1.4404
3A	Clamp	AISI 316 / 1.4401
4	* Valve stem	AISI 316L / 1.4404
5	* Soft plug	** EPDM; PTFE; FPM
6	* Valve plug	AISI 316L / 1.4404
7	* Upper diaphragm	EPDM
8	* Lower diaphragm	PTFE (Gylon)
9	Diaphragm plate	AISI 316L / 1.4404
10	* O-ring	EPDM
11	Diaphragm plate	AISI 316L / 1.4404
12	Stem guide	AISI 316L / 1.4404
12A	Plain bearing	Bronze
13	Spring plate	AISI 316L / 1.4404
14	Nut	AISI 304 / 1.4301
15	Washer	AISI 304 / 1.4301
16	* Adjustment spring	AISI 302 / 1.4300
17	Top spring plate	AISI 316L / 1.4404
18	Retaining washer	Stainless steel A2-70
19	Adjustment nut	AISI 316L / 1.4404
20	Adjustment screw	Brass
21	O-ring	NBR
22	Bearing	Corrosion resistant steel
23	Ext. bowed shaft ring	Stainless steel
24	Cover nut	Plastic
25	* O-ring	NBR

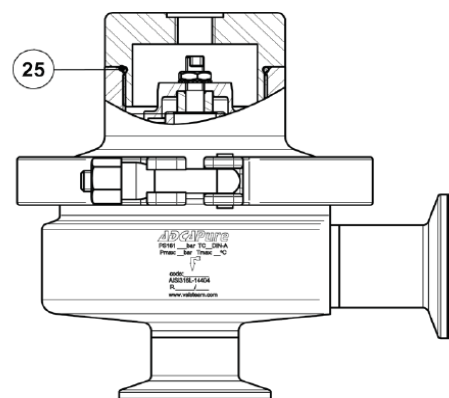
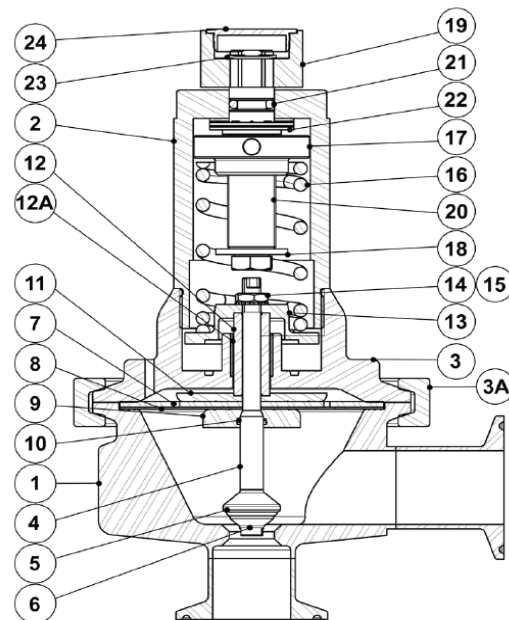

Dome-loaded top

* Available spare parts; ** Others according to fluid.
 Remarks: FDA / USP Class VI seals certificate on request.
 All valves have a serial number. In case of non-standard valves, this number must be supplied if spare parts are ordered.

OPTIONS		
ADJUSTMENT SCREW WITH TOP CAP	PRESSURE GAUGE CONNECTION	LEAKAGE LINE CONNECTION
