

Model GS27

PINCH VALVES

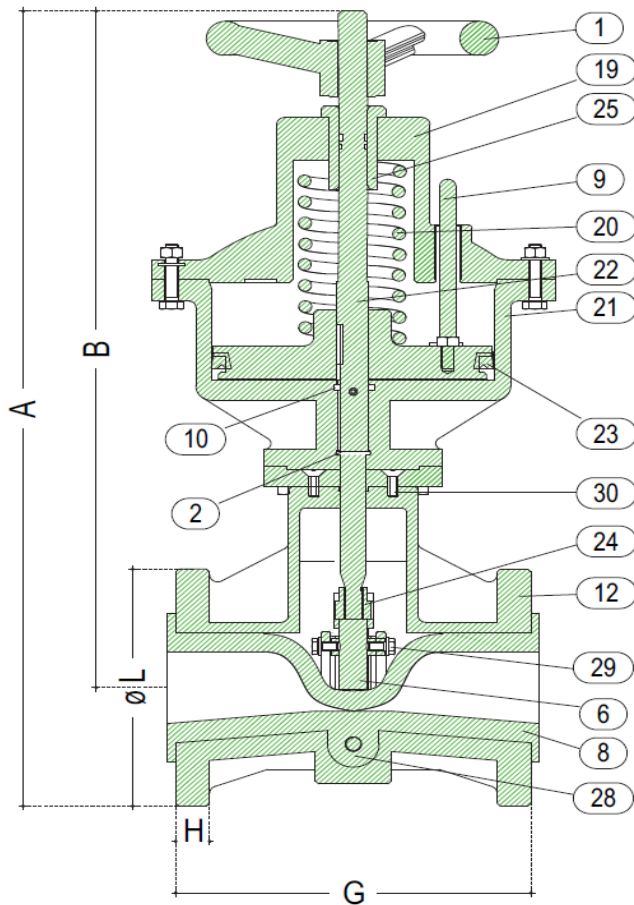
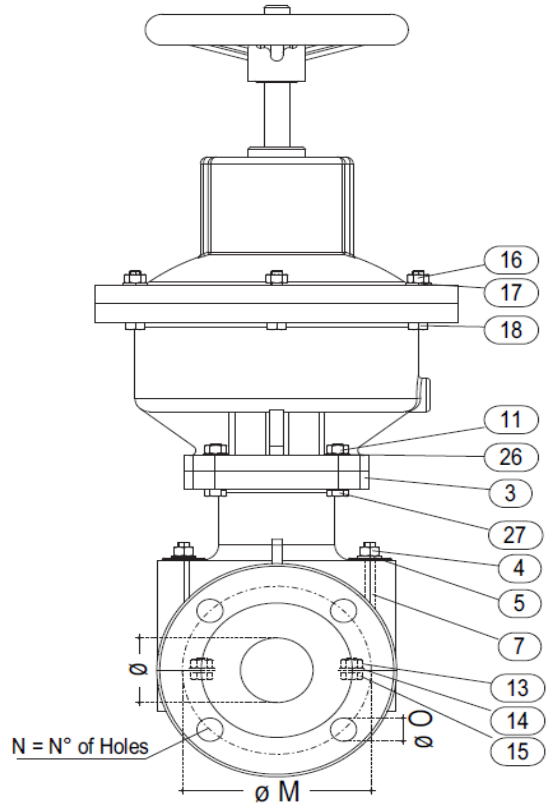

DETAILS

1	WHEEL
2	OR
3	SUPPORT
4	HEXAGON NUT
5	WASHER
6	PLUG
7	TIE ROD
8	SLEEVE
9	GUIDE PIN
10	GASKET
11	HEXAGON NUT
12	VALVE UPPER-LOWER BODY
13	HEXAGON NUT
14	WASHER
15	HEXAGON BOLT
16	HEXAGON NUT
17	WASHER
18	HEXAGON BOLT
19	COVER
20	SPRINGS
21	CYLINDER
22	PISTON
23	"V" GASKET
24	BRONZE NUT
25	BUSHING AND COVER
26	WASHER
27	HEXAGON BOLT
28	SCREW SOCKET
29	CLAMPING SCREW FOR BUSHING AND WASHER
30	HEXAGON SOCKET HEAD COUNTERSUNK HEAD SCREWS



AIR PRESSURE REQUIRED KG/CM ²								
dn	20	25	30	40	50	80	100	150
min.	4	4	4	4	4	4	4	4
max.	6	6	6	5	5	5	5	5

PRESSURE DETAILS UNI_1284				
DN	P.N.	HYDRAULIC TEST kg/cm ²		WORKING PRESSURE kg/cm ²
		OPEN	CLOSE	
20	4	10	4	3
25	4	10	4	3
30	4	10	4	3
40	4	10	4	3
50	4	10	4	3
80	4	10	4	3
100	4	10	4	3
150	4	10	4	3

NOTE: For different pressure details please ask the DPT

DIMENSIONS					UNI PN 10				ASA 150			
Ø	A	B	G	H	L	M	N	O	L	M	N	O
20	389,5	337	140	14	105	75	4	14	98	70	4	16
25	418,5	361	150	14	115	85	4	14	108	80	4	16
30	496	426	170	16	140	100	4	18	118	90	4	16
40	525	450	190	18	150	110	4	18	127	98	4	16
50	535,5	453	220	21	165	125	4	18	152	120	4	19
80	667	567	300	22	200	160	4	18	190	152	4	19
100	812	702	340	22	220	180	8	18	229	190	8	19
150	1130	987	470	24	285	240	8	22	280	241	8	22