

Model GS21

PINCH VALVES

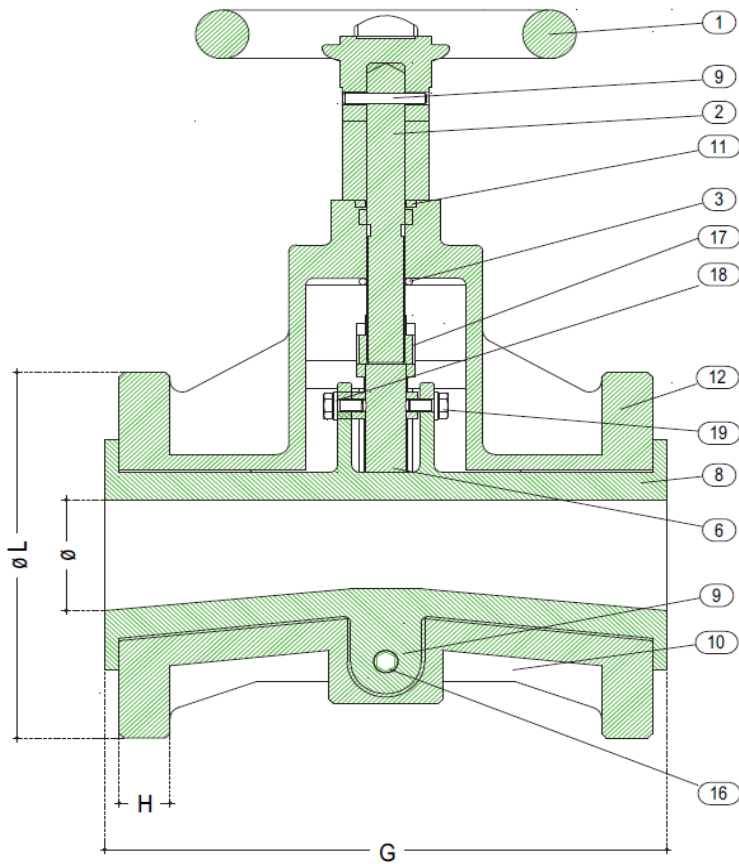
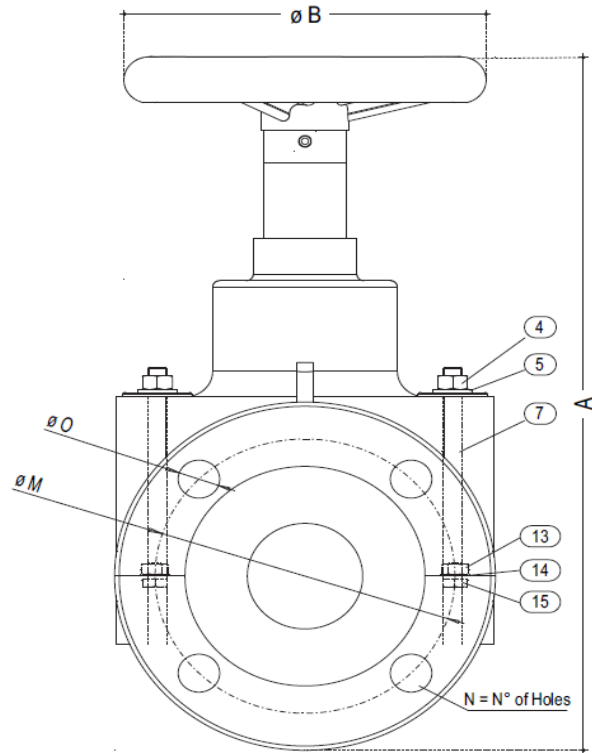

DETAILS

1	WHEEL
2	LEAD SCREW
3	WASHER
4	HEXAGON NUT
5	WASHER
6	PLUG
7	TIE ROD
8	SLEEVE
9	SOCKET
10	VALVE LOWER BODY
11	GASKET
12	VALVE UPPER BODY
13	HEXAGON NUT
14	WASHER
15	HEXAGON BOLT
16	SCREW SOCKET
17	BRONZE NUT
18	WASHER
19	CLAMPING SCREW FOR BUSHING



PRESSURE DETAILS UNI_1284

DN	P.N.	HYDRAULIC TEST kg/cm ²		WORKING PRESSURE kg/cm ²
		OPEN	CLOSE	
20	5	10	5	4
25	5	10	5	4
30	5	10	5	4
40	5	10	5	4
50	5	10	5	4
80	5	10	5	4
100	5	10	4	3

NOTE: For different pressure details please ask the DPT

WEIGHT KG
ALUMINIUM

2,100
2,380
3,800
5,480
6,900
13,500
19,900
37,000

Ø	DIMENSIONS				UNI PN 10				ASA 150			
	A	B	G	H	L	M	N	O	L	M	N	O
20	185	110	140	14	105	75	4	14	98	70	4	16
25	199	130	150	14	115	85	4	14	108	80	4	16
30	235	130	170	16	140	100	4	18	118	90	4	16
40	267	175	190	18	150	110	4	18	127	98	4	16
50	292	175	220	21	165	125	4	18	152	120	4	19
80	350	210	300	22	200	160	4	18	190	152	4	19
100	425	255	340	22	220	180	8	18	229	190	8	19
150	601	370	470	24	285	240	8	22	280	241	8	22