

Model GS55 HW

DIAPHRAGM VALVES

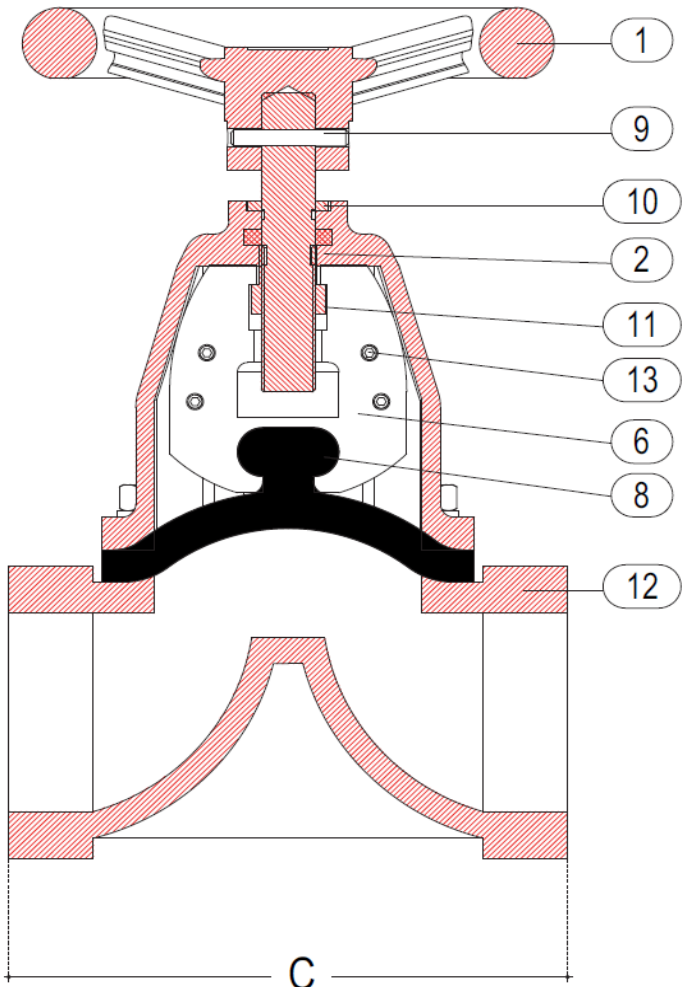

DETAILS	
1	CONTROL WHEEL
2	LEAD SCREW
3	COVER
4	HEXAGON NUT
5	WASHER
6	PLUG
7	BOLT
8	DIAPHRAGM
9	SOCKET
10	GASKET
11	BRONZE NUT
12	VALVE BODY
13	CLAMPING SCREW FOR BUSHING

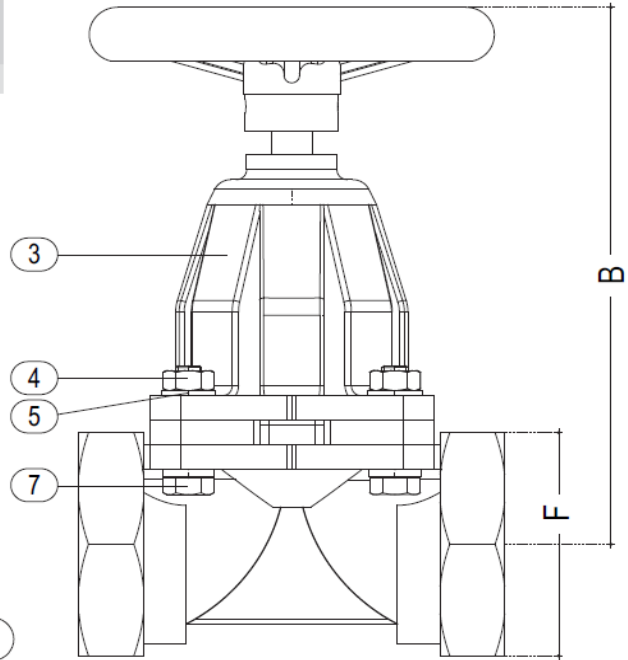

WEIGHT KG C.I
2,400
3,900
4,100
6,700
8,300
12,400
17,600
24,000

DIMENSIONS				
Ø	B	C	F	
1/2 GAS	60	50	45	
3/4 GAS	73	65	50	
1 GAS	125	108	60	
1 1/4 GAS	143	121	72	
1 1/2 GAS	180	140	80	
2 GAS	187	165	90	
2 1/2 GAS	232	204	120	
3 GAS	260	254	140	

PRESSURE DETAILS UNI_1284				
DN	P.N.	HYDRAULIC TEST kg/cm ²		WORKING PRESSURE kg/cm ²
		OPEN	CLOSE	
1/2 GAS	14	15	14	13
3/4 GAS	14	15	14	13
1 GAS	14	15	14	13
1 1/4 GAS	14	15	14	13
1 1/2 GAS	14	15	14	13
2 GAS	14	15	14	13
2 1/2 GAS	14	15	14	13
3 GAS	14	15	14	13

NOTE: For different pressure details please ask the DPT