

Model GS51DIN HW

DIAPHRAGM VALVES

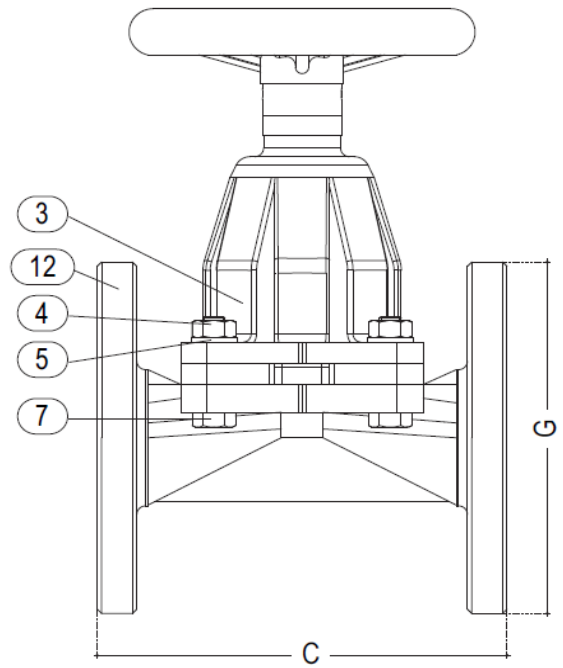
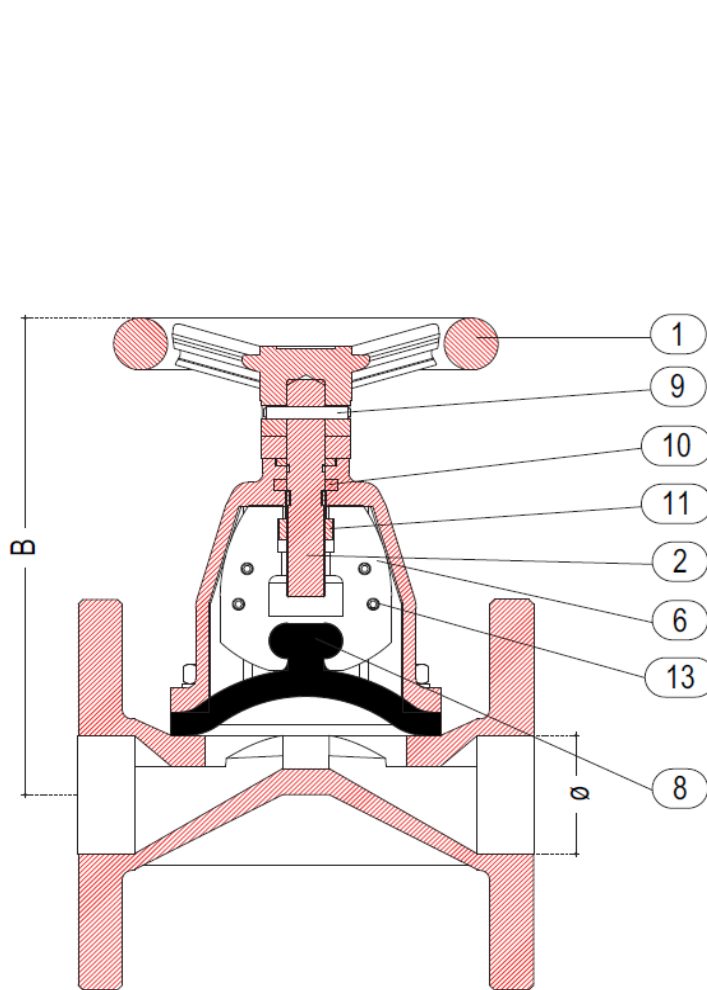

DETAILS	
1	CONTROL WHEEL
2	LEAD SCREW
3	COVER
4	HEXAGON NUT
5	WASHER
6	PLUG
7	STUD BOLT
8	DIAPHRAGM
9	SOCKET
10	GASKET
11	BRONZE NUT
12	VALVE BODY
13	CLAMPING SCREW FOR BUSHING

PRESSURE DETAILS UNI_1284				
DN	P.N.	HYDRAULIC TEST kg/cm ²		WORKING PRESSURE kg/cm ²
		OPEN	CLOSE	
15	14	15	14	13
20	14	15	14	13
25	14	15	13	12
30	13	15	13	12
40	12,5	15	12,5	11,5
50	12,5	15	12,5	11,5
60	11	15	11	10
75	10,5	15	10,5	9,5
100	10,5	15	10,5	9,5
125	9	13	9	8
150	8,7	13	8,7	7,7
200	7	13	7	6
250	6	8	6	6
300	6	8	6	6

NOTE: For different pressure details please ask the DPT



WEIGHT KG	
C.I. unlined	C.I. ebonite lined
2,100	2,300
4,000	4,300
4,500	4,800
7,500	8,000
8,500	8,500
12,200	13,000
18,000	19,500
26,000	28,000
39,000	41,000
57,000	60,000
75,000	89,000
155,000	164,000
242,000	250,000
340,000	350,000

DIMENSIONS C.I. UNLINED					
Ø	B	C	G (UNI)	G (ASA)	
15	87,5	130	95	90	
20	112,5	150	105	98	
25	117,5	160	115	108	
30	135	180	140	118	
40	170	200	150	127	
50	187,5	230	165	152	
60	232,5	280	185	178	
75	260	310	200	190	
100	315	350	220	229	
125	400	400	250	254	
150	442,5	480	285	280	
200	585	590	340	343	
250	655	730	395	406	
300	718	850	445	483	

DIMENSIONS C.I. EBONITE LINED					
Ø	B	C	G (UNI)	G (ASA)	
15	92,5	130	95	90	
20	117,5	150	105	98	
25	122,5	160	115	108	
30	140	180	140	118	
40	175	200	150	127	
50	192,5	230	165	152	
60	237,5	290	185	178	
75	265	310	200	190	
100	320	350	220	229	
125	405	400	250	254	
150	447,5	480	285	280	
200	590	600	340	343	
250	660	730	395	406	
300	723	850	445	483	