

**SANITARY PILOT OPERATED
 PRESSURE REDUCING VALVE
 P147**

DESCRIPTION

The ADCA P147 series sanitary pilot operated pressure reducing valves are designed for use with clean air, nitrogen, carbon dioxide, oxygen, argon and other gases or liquids compatible with the construction materials and valve design.

This valve is specifically designed for the high purity gas systems found in the pharmaceutical, cosmetic, fine chemical and food & beverage processes.

MAIN FEATURES

- Precise control of downstream pressure from 0,2 to 8 bar.
- Completely machined from 316L stainless steel bar stock, no castings or forgings are used.
- FDA / USP Class VI compliant seals.
- Guided piston and valve stem.
- Non-rising adjustment knob.

STANDARD SURFACE FINISH

- Internal wetted parts: $\leq 0,51$ micron Ra – SF1.
- External: $\leq 0,76$ micron Ra – SF3.
- Other surface conditions see IS PV20.00 E – Technical information.
- Ultrasonic cleaning.

- OPTIONS:** Bottom cover with drain connection.
 Leakage line connection 1/8" (captured vent).
 Gauge connections on body.
- USE:** Clean air, nitrogen, carbon dioxide, oxygen, argon and other gases compatible with the construction.
 Clean steam (under special request).

AVAILABLE MODELS: P147.

SIZES: 2 1/2" to 3"; DN 65 to DN 80.

REGULATING RANGES: 0,2 – 1,5 bar; 0,3 – 3 bar; 2 – 8 bar.

CONNECTIONS: ASME BPE and DIN clamp ferrules.
 Others on request.

PACKAGING: Assembling and packaging in a clean room certified according to ISO 14644-1.
 The product is end capped and sealed with recyclable thermo-shrinkable plastic film, to avoid contamination.

INSTALLATION: Horizontal installation.
 See IMI – Installation and maintenance instructions.

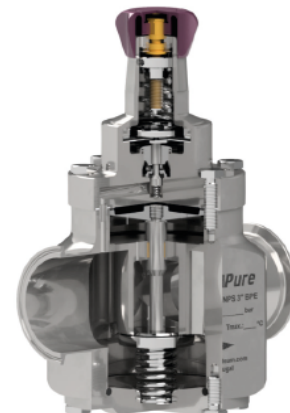

LIMITING CONDITIONS	
Valve model	P147
Body design conditions	PN 16
Maximum upstream pressure	16 bar
Maximum downstream pressure	8 bar
Minimum downstream pressure	0,2 bar
Maximum design temperature *	150 °C

* Others on request.

CE MARKING – GROUP 2 (PED – European Directive)	
PN 16	Category
2 1/2" to 3" – DN 65 to 80	1 (CE marked)

FLOW RATE COEFFICIENTS (m ³ /h)				
SIZE	BPE		DIN	
	2 1/2"	3"	DN 65	DN 80
Kvs	41	46	41	46

DIMENSIONS (mm) ASME BPE							
SIZE	A	B	C	D	F	H	WEIGHT (kg) *
2 1/2"	197	307	89	134	91	66	17,1
3"	197	307	89	134	106	81	16,8

* Valves with nylon adjustment knob weigh 0,3 kg less.

DIMENSIONS (mm) DIN							
SIZE	A	B	C	D	F	H	WEIGHT (kg) *
DN 65	196	307	89	134	91	66	17,1
DN 80	196	307	89	134	106	81	17,4

* Valves with nylon adjustment knob weigh 0,3 kg less.
 Remark: Clamp ferrules according to DIN 32676-A.

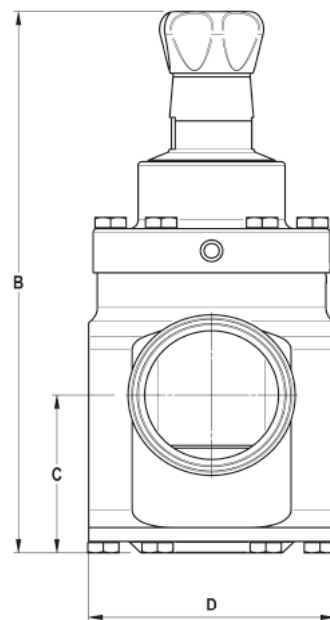
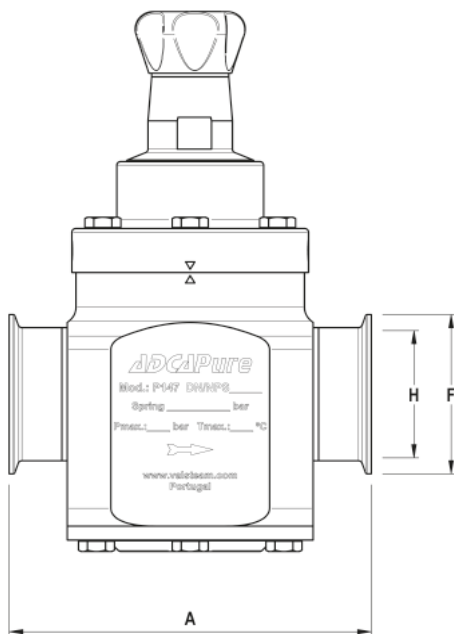

MATERIALS		
POS. N°	DESIGNATION	MATERIAL
1	Valve body	AISI 316L / 1.4404
2	* Plug	AISI 316L / 1.4404
3	* Plug seal	EPDM; TFM 1600 **
4	* Main valve spring	AISI 316 / 1.4401
5	* O-ring	EPDM
6	Bottom cover	AISI 316L / 1.4404
7	* Stem	AISI 316L / 1.4404
8	* Plain bearing	PTFE
9	Piston	AISI 316L / 1.4404
10	* O-ring	EPDM
11	Positioning pipe	AISI 316L / 1.4404
12	Gasket	PTFE
13	Pilot valve body	AISI 316L / 1.4404
14	Bolts	AISI 304 / 1.4301
15	Seat	AISI 316L / 1.4404
16	* O-ring	EPDM
17	* Pilot valve seat	EPDM
18	* Pilot valve plug	AISI 316L / 1.4404
19	* Valve spring	AISI 316 / 1.4401 electropolished
20	* Lower diaphragm	PTFE (Gylon)
21	* Upper diaphragm	EPDM
22	* Washer	AISI 304 / 1.4301
23	Spring plate	AISI 316 / 1.4401
24	Pusher disc	AISI 316L / 1.4404
25	Washer	AISI 304 / 1.4301
26	Nut	AISI 304 / 1.4301
27	Adjustment spring	AISI 302 / 1.4310
28	Spring plate	AISI 316 / 1.4401
29	Adjustment screw	Brass
30	Retaining washer	AISI 304 / 1.4301
31	Adjustment knob	AISI 316L / 1.4404 Nylon
32	O-ring	NBR
33	Bearing	Corrosion resistant steel
34	Ext. bowed shaft ring	Stainless steel
35	Cover nut	Plastic
36	Spring cover	AISI 316L / 1.4404

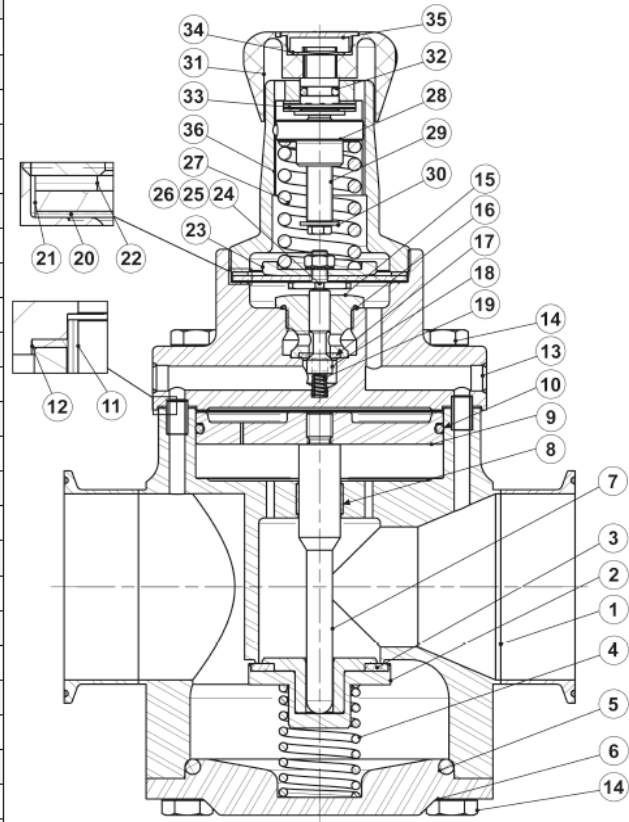

* Available spare parts ; ** Others according to fluid.

All valves have a serial number. In case of non-standard valves, this number must be supplied if spare parts are ordered.