

**SANITARY CHECK VALVE
 SRT10**

DESCRIPTION

The SRT10 all stainless steel disc check valve has a compact design and is specially designed for use with clean steam, hot condensate and other process fluid applications.

They are particularly recommended for high purity applications.

MAIN FEATURES

Compact design.

Completely machined from bar stock material, no castings or forgings are used on the standard version.

STANDARD SURFACE FINISH

Internal wetted parts: ≤ 0,51 micron Ra – SF1.

External: ≤ 0,76 micron Ra – SF3.

Other surface conditions see IS PV20.00 E – Technical information.

Ultrasonic cleaning.

USE: Clean steam, water and other gases and liquids compatible with the construction.

AVAILABLE

MODELS: SRT10 – Vertical installation.
 SRTH10 – Horizontal installation.

SIZES: 1/2" to 4".

CONNECTIONS: Clamp ends or others on request.

PACKAGING: Assembling and packaging in a clean room certified according to ISO 14644-1.
 The product is end capped and sealed with recyclable thermo-shrinkable plastic film, to avoid contamination.

INSTALLATION: Vertical or horizontal according to the selected reference and type of fluid.



CE MARKING (PED – European Directive)	
Sizes	Category
1/2" to 4"	SEP

LIMITING CONDITIONS	
Valve model	SRT10
Body design conditions	PN10
Max. operating pressure	10 bar
Max. operating temp. – EPDM seals	150 °C
Max. operating temp. – FEP seals *	200 °C
Minimum operating temperature	-10 °C

Higher and lower limits on request.

* FEP – Silicone.

VALVE DIMENSIONS (mm) ASME BPE									
SIZE	A1	A2	A3	D	E	F	G	H	WGT. (kg)
1/2"	50	95	50	11,8	61	25	12,7	9,4	0,4
3/4"	50	95	50	8,6	61	25	19,05	15,8	0,5
1"	60	98	60	5,5	61	50,5	25,4	22,1	0,6
1 1/2"	69	109	69	11,1	90	50,5	38,1	34,8	1,1
2"	84	78	122	11,3	104	64	50,8	47,5	1,4
2 1/2"	89	92	89	9,9	119	77,5	63,5	60,2	1,8
3"	98	133	98	11,1	134	91	76,2	72,9	2,6
4"	109	144	109	14,3	170	119	101,6	97,38	4,9

Face to face dimensions are not standardized. Different dimensions available on request.

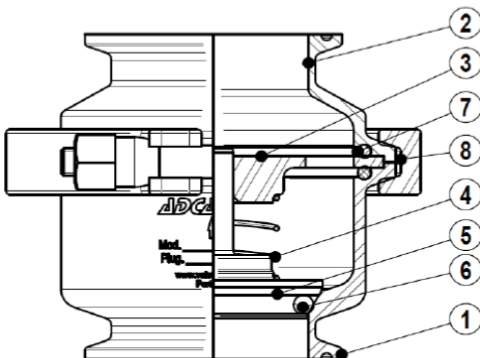
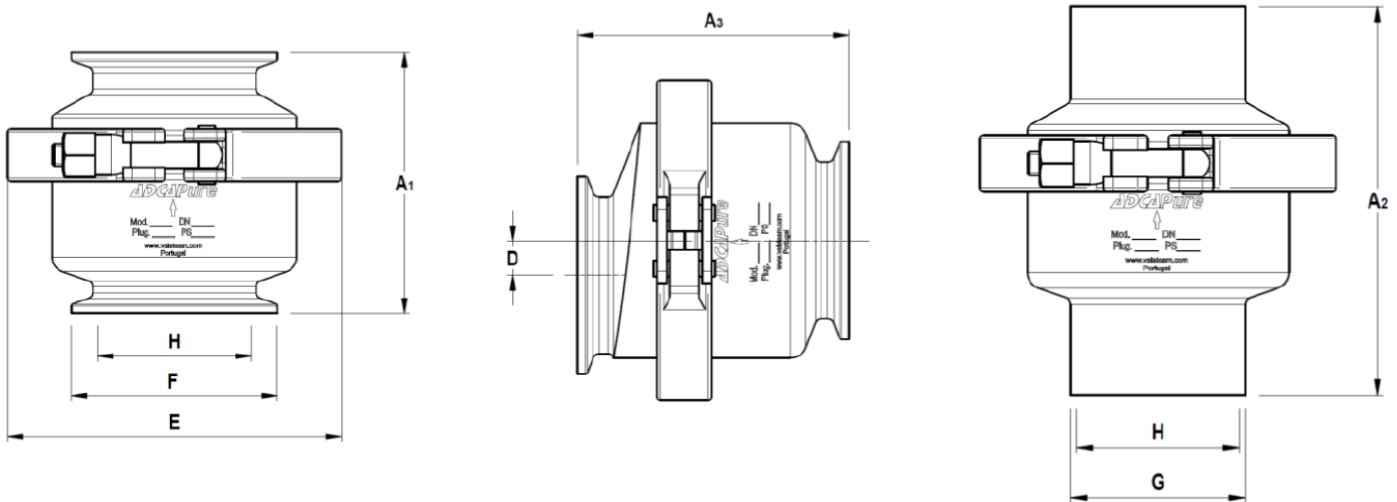

MATERIALS		
POS. N°	DESIGNATION	MATERIAL
1	Valve inlet body	AISI 316L / 1.4404
2	Valve outlet body	AISI 316L / 1.4404
3	Guide plate	AISI 316L / 1.4404
4	Spring	AISI 316 / 1.4401 electropolished
5	* Valve and stem	AISI 316L / 1.4404
6	* Valve seal	EPDM **
7	* Body seals	EPDM **
8	Safety clamp	AISI 316 / 1.4401

* Available spare parts.

** Available on request: FEP – Silicone and others.

Remarks: FDA / USP Class VI seals certificate on request.

All valves must have a serial number. In case of non-standard valves this number must be supplied if spare parts are ordered.