

Type test approved safety valves angle-type for industrial applications

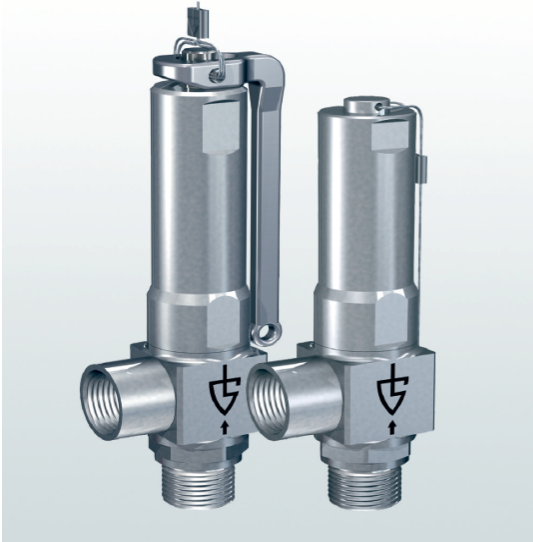

420

Safety valves made of stainless steel, angle-type with threaded connections

→ **Series 420**



■ SUITABLE FOR

Liquids	neutral and non-neutral	
Air, gases and vapours	neutral and non-neutral	
Steam		

■ EXAMPLES OF USE

For the protection of:

- pressure tanks and -systems for neutral / non-neutral vapours, gases and liquids
- steam boilers and steam plants

Please observe plant-specific regulations and use of appropriate valve version and sealing material.

- chemical plants, biogas plants
- process technology
- desalination plants
- process equipment construction and medical technology
- shipbuilding industry and marine equipment
- secondary areas in the food-, beverage-, pharmaceutical- and cosmetics-industries
- offshore-applications
- general applications with screwed pipe connections

Safety valves are set and sealed at the factory.

■ APPROVALS

TÜV-Type test approval 2069	D/G, F, F/K/S ¹
EC type examination	S/G, L, F/K/S ¹
KGS	G
TR ZU 032/2013 - TR ZU 010/2011	D/G (S/G), F (L), F/K/S ¹

Requirements

AD 2000 Data sheet A2	DIN EN ISO 4126-1
TRD 421	PED 2014/68/EU
TRB 801 No. 22 and No. 23 ¹	KGS AA 319

Classification society

DNVGL	DNVGL
Lloyd's Register EMEA	LR EMEA
American Bureau of Shipping	ABS
Bureau Veritas	BV
Russian Maritime Register of Shipping	RS



■ MATERIAL



■ SPECIFICATION

		
1/4" – 3/8"	- 40°C to + 260°C depending on version	0,5 – 50 bar depending on version

■ MATERIALS

Component	Material	DIN EN	ASME
Inlet body	Stainless steel	1.4404	316 L
Outlet body	Stainless steel	1.4404	316 L
Internal parts	Stainless steel	1.4404	316 L
Spring	Stainless steel	1.4310	302
Metallic bellows (optional)	Stainless steel	1.4571	316 Ti
PTFE-bellows (optional)	PTFE	PTFE	PTFE

¹only for versions with bellows

Series 420 ■ VALVE VERSION

t	gastight version of spring housing	for neutral and non-neutral media without counter pressure. The environment is protected from being affected by the medium.
tb	gastight version with bellows	for neutral and non-neutral media. spring and moving parts as the environment are protected from being affected by the medium. Version of bellows dependign on set pressure: DN8: 0,5 to 9 bar PTFE bellows; 9,1 to 50 bar stainless steel bellows DN10: 0,5 to 7 bar PTFE bellows; 7,1 to 50 bar stainless steel bellows

■ MEDIUM

GF	gaseous and liquid	Air, vapours, gases, liquids and - depending on seal - also for steam Only for steam boilers <10l and d ₀ minimum 6mm, i.e. only DN10 usable.
-----------	--------------------	---

■ TYPE OF LIFTING MECHANISM

L	Lifting lever
0	without lifting device

■ AVAILABLE NOMINAL DIAMETERS AND CONNECTION SIZES

Nominal diameter DN		8			10		
Inlet		1/4" (8)	SV (8mm)	SV (10mm)	3/8" (10)	SV (10mm)	SV (12mm)
Outlet	3/8" (10)	■	■	■	■	■	■
	SV (12mm)	■	■	■	■	■	■

■ TYPE OF CONNECTION INLET / OUTLET THREADED CONNECTIONS

m / f	Standard	Male thread BSP-P / Female thread BSP-P	DIN EN ISO 228-1 / DIN EN ISO 228-1
SV / f		Cutting ring threaded connection / female thread BSP-P	EN ISO 8434-1 / DIN EN ISO 228-1
SV / SV		Cutting ring threaded connection / Cutting ring threaded connection	EN ISO 8434-1 / EN ISO 8434-1

■ SEALS

EPDM	Ethylene propylene diene	Elastomere moulded seal with metallic support	-40°C to +170°C
FKM	Fluorcarbon	Elastomere moulded seal with metallic support	-20°C to +200°C
FFKM	Perfluorinated rubber	Elastomere moulded seal with metallic support	-10°C to +260°C

■ **NOMINAL DIAMETERS, CONNECTIONS, INSTALLATION DIMENSIONS**

Series 420: Connection, installation dimensions, ranges of adjustment			
Nominal diameter	DN	8	10
Connection DIN EN ISO 228	G	1/4" (8)	3/8" (10)
Outlet DIN EN ISO 228	G1	3/8" (10)	3/8" (10)
Installation dimensions in mm	L	25	25
	Lmax	45	45
	H	75	75
	H1	87	87
	Hmax	93	93
	h	32	32
	h1	12	12
	SW	20	20
	do	4,5	6
Weight	kg	0,31 / 0,36*	0,23 / 0,28*
Range of adjustment	bar	0,5-50	0,5-50

* Weight indications for valve with lever

■ **MAIN DIMENSIONS, INSTALLATION DIMENSIONS**

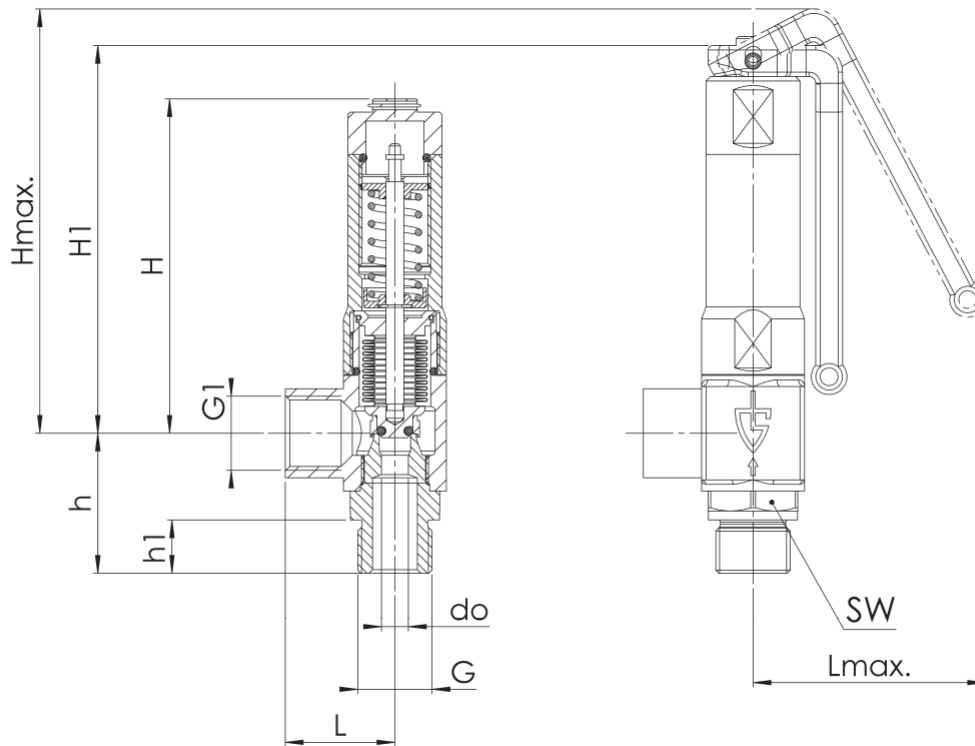

■ CAPACITY TABLE ACC. TO ISO 4126-1 / AD2000 A2

Series 420: Blowing-off rates at 10% above set pressure								
Nominal diameter DN		8			10			
Set pressure bar		I	II	III	I	II	III	III
Air I Nm ³ /h	0,5	11	-	0,35	16	13	0,65	
	1	15	-	0,48	24	19	0,88	
	1,5	20	-	0,58	32	25	1,07	
Steam II kg/h	2	24	-	0,67	40	32	1,24	
	2,5	28	-	0,75	47	37	1,38	
	3	33	-	0,82	55	43	1,52	
Water III m ³ /h	3,5	37	-	0,89	62	48	1,64	
	4	41	-	0,95	69	53	1,75	
	4,5	45	-	1,01	76	58	1,86	
	5	49	-	1,06	83	64	1,96	
	5,5	53	-	1,12	90	69	2,05	
	6	58	-	1,16	96	74	2,14	
	6,5	62	-	1,21	103	79	2,23	
	7	66	-	1,26	110	85	2,32	
	7,5	70	-	1,30	117	90	2,40	
	8	74	-	1,35	124	95	2,48	
	8,5	78	-	1,39	131	100	2,55	
	9	83	-	1,43	138	105	2,63	
	9,5	87	-	1,47	145	111	2,70	
	10	91	-	1,50	152	116	2,77	
	11	99	-	1,58	166	126	2,90	
	12	108	-	1,65	180	136	3,03	
	13	116	-	1,71	194	147	3,16	
	14	124	-	1,78	208	157	3,28	
	15	133	-	1,84	222	167	3,39	
	16	141	-	1,90	236	178	3,50	
17	149	-	1,96	250	188	3,61		
18	158	-	2,02	264	198	3,71		
19	166	-	2,07	278	208	3,82		
20	174	-	2,13	292	218	3,92		
21	183	-	2,18	306	229	4,01		
22	191	-	2,23	320	239	4,11		
23	199	-	2,28	334	249	4,20		
24	208	-	2,33	348	260	4,29		
25	216	-	2,38	362	270	4,38		
26	224	-	2,43	376	280	4,46		
27	233	-	2,47	390	291	4,55		
28	241	-	2,52	404	301	4,63		
29	249	-	2,56	418	312	4,72		
30	258	-	2,60	432	321	4,80		
32	274	-	2,69	460	342	4,95		
34	291	-	2,77	488	363	5,11		
36	308	-	2,85	515	384	5,25		
38	324	-	2,93	543	404	5,40		
40	341	-	3,01	571	425	5,54		
42	358	-	3,08	599	446	5,67		
44	374	-	3,15	627	467	5,81		
46	391	-	3,23	655	488	5,94		
48	408	-	3,30	683	509	6,07		
50	424	-	3,36	711	530	6,19		