

# Minimatic

Electric Control Valves



**HIGH QUALITY • COMPETITIVE • COMPACT**



### Electric Minimatic Control Valves

2-Way On/Off or Modulating

3-Way Mixing or Diverting

Bronze - DN15 to DN50 Screwed

DN15 to DN40 Flanged

Stainless Steel - DN15 to DN25 Screwed only

Compact Competitive Flow Control Valves

The Minimatic Control Valve provides efficient On/Off or Modulating Control of liquids, steam, air or gases.

### Main Features

- Lightweight for ease of handling
- Compact for when space is limited
- Robust design for minimal maintenance
- All valves incorporate our new “Low Fugitive Emission” maintenance free gland seals
- 2 way or 3 way body configurations
- Cast Bronze for pressures up to 16 Bar and 180°C
- Investment cast 316 stainless steel bodies for pressures up to 25 Bar and 180°C
- On/Off or modulating control options
- Stainless steel plug & spindle assemblies
- PTFE soft seat for On/Off duties
- Stainless steel seat for modulating duties
- Equal percentage or linear characteristic
- For use on liquid, steam or gas applications



# Minimatic

## Electric Control Valves

### On/Off and Modulating Control

To meet the growing demand for electrically operated valves Northvale introduced a range of lightweight, high output, linear electric actuators to fit all sizes of MINIMATIC valves. Available in 2-Way and 3-Way body styles with soft seats for on/off control, profiled stainless steel trim for modulating control.

### Valve Options

	On/Off	Modulating
2-Way Screwed	Fig 71E	Fig 74E
3-Way Screwed	Fig 72E	Fig 75E
2-Way Flanged	Fig 7700E	Fig 77E
3-Way Flanged	Fig 7800E	Fig 78E

### Actuator Options

Actuators can be selected to suit different supply conditions and functions. For all valves – 24 and 220/240 vac

Standard actuators will remain 'Stay Put' at their last position in the event of a power supply failure.

Spring return actuators are available for 24 vac supply systems only and can be arranged to fail open or closed in the event of a power supply failure.

### Control Signals

Modulating valves can be controlled by input signals either 0-10 volt or 4-20mA by simply selecting the appropriate connections within the enclosure. Valves can be easily changed from one system to the other without the need to return them to the factory.

The drawings depict Fig. 71E and Fig. 72E valve arrangements but are typical for all the models detailed in the table below.

### Installation

Valves may be installed with the actuators in the horizontal position but never with the actuator upside down below the valve.

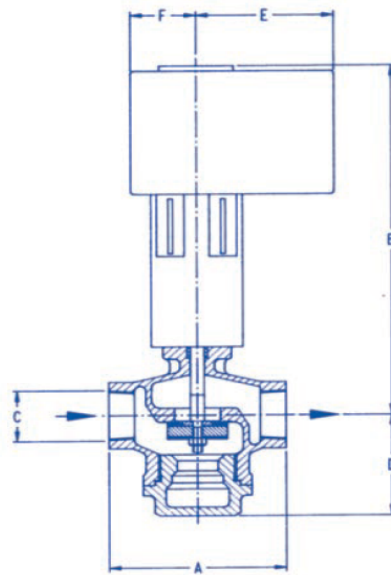

MVL Actuator

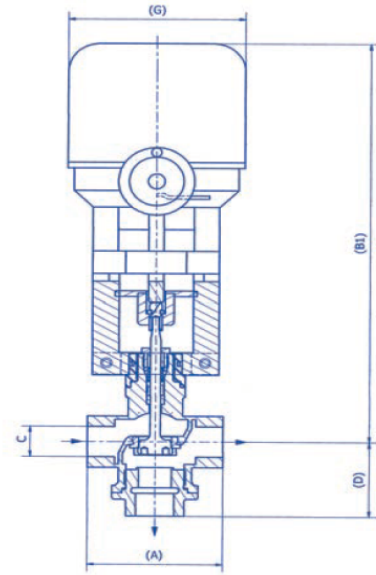

GEA Actuator

### Screwed Valves Fig. 71E, 72E, 74E, 75E

Size	Kv	A	B	B1	C BSP Taper	D	D	E	F	G
			MVL	GEA		2-Way	3-Way	MVL	MVL	GEA
1/2"	2.5 5	152	313	336	1/2"	54	70	109	70	140
3/4"	2.5 6	88	318	336	3/4"	54	54	109	70	140
1"	10	104	319	342	1"	66	66	109	70	140
1 1/2"	25	155	338	397	1 1/2"	99	99	109	70	140
2"	40	178	343	402	2"	99	99	109	70	140

### Flanged Valves Fig. 77E, 78E, 7700E, 7800E

Size	Kv	A	B	B1	C Dia NB	D	D	E	F	G
			MVL	GEA		2-Way	3-Way	MVL	MVL	GEA
1/2"	2.5 5	152	313	336	15	54	70	109	70	140
3/4"	2.5 6	152	313	336	20	54	70	109	70	140
1"	10	159	319	342	25	66	76	109	70	140
1 1/2"	10	165	338	397	40	99	89	109	70	140

### Max Δp across Valve bar g

Size	Stay Put Actuator	Spring Return Actuator
1/2"	16	8
3/4"	16	8
1"	12	5
1 1/2"	12	5
2"	8	3.5

### Pressure Drop Capability

The standard actuators are capable of handling the maximum pressure differentials shown in the table. Unlike diaphragm actuators these valves apply to both 2-Way and 3-Way valves.

#### Note:

Reduced trim Kv=2.5 only available Fig. 74E, 75E, 77E and 78E