

BIMETALLIC STEAM TRAPS AND AIR ELIMINATORS
BM 20 SS
 (Stainless steel)
 (DN ½" – 1"; DN 15 – 25)

DESCRIPTION

BM20SS series bimetallic steam traps and air eliminators are simple and robust traps, recommended for steam process applications where condensate sensible heat can be recovered, steam tracing lines, drip points, storage tank coils, steam air venting, etc.

The use of condensate sensible heat reduces the steam consumption.

Connections are female screwed or flanged.

MAIN FEATURES

Modulating discharge.

Discharges condensate below steam temperature.

Excellent air discharge.

Operates on superheated steam.

Unaffected by water hammer and vibrations.

Built-in strainer.

USE: Saturated and superheated steam.

AVAILABLE

MODELS: BM20SS

SIZES: DN ½" to 1"; DN15 to DN25.

CONNECTIONS: Female screwed ISO 7/1 Rp (BS21)

Flanged EN1092-1 PN40 or ANSI

INSTALLATION: Horizontal installation recommended, can be installed in any position.

See IMI installation and maintenance instructions.

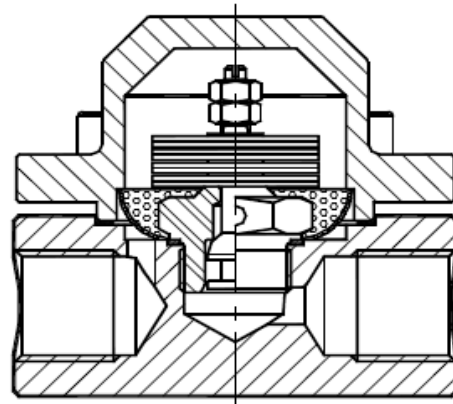
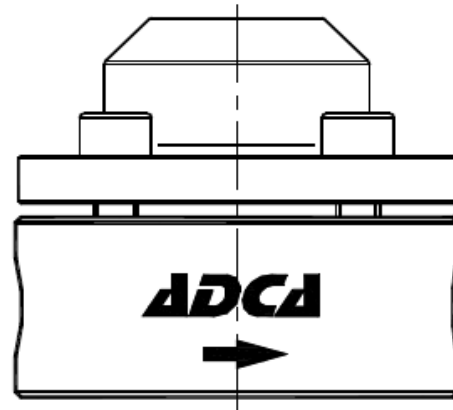

BODY LIMITING CONDITIONS		
FLANGED PN40 / ANSI 300 *	FLANGED ANSI 150 **	RELATED TEMP.
ALLOW. PRES.	ALLOW. PRES.	
40 bar	18,4 bar	50 °C
36,3 bar	14,8 bar	150 °C
33,7 bar	13,6 bar	200 °C
31,8 bar	12 bar	250 °C

PMO - Max. operating pressure 17 bar

TMO - Max. operating temperature 250 °C

* According to EN1092-1:2007 ; ** Acc. to EN1759-1:2004

Body limiting conditions PN40 or below, depending on the type of connection adopted. Rating PN40 for thread, SW and BW.

FLOW RATE CAPACITY IN Kgs/h											
MODEL	SIZE DN	DIFFERENTIAL PRESSURE (bar)									
		0,5	1	2	4	6	8	10	12	14	17
BM20SS	15 - 25 A	125	200	320	410	445	485	500	540	580	600
BM20SS	15 - 25 B	450	700	1000	1220	1340	1450	1560	1650	1780	1850

A = Condensate discharge at 10°C below saturation temperature. B = Cold water capacity at about 20°C.

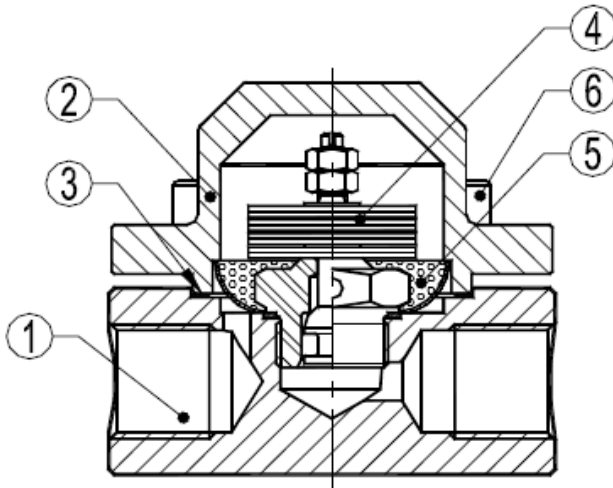

MATERIALS		
POS.N r.	DESIGNATION	MATERIAL
1	Body	AISI316 / 1.4401
2	Cover	AISI316 / 1.4401
3	* Gasket	St.St./Graphite
4	* Valve assy.	Bimetal
5	* Strainer screen	AISI304 / 1.4301
6	Bolts	St.Steel A2-70

* Available spare parts

DIMENSIONS (mm)										
Screwed and SW *					EN PN16/40		ANSI 150		ANSI 300	
SIZE DN	A	B	C	WGT. Kgs	E	WGT. Kgs	E	WGT. Kgs	E	WGT. Kgs
15-1/2"	80	55	17	1,8	150	3,3	150	2,8	150	3,6
20-3/4"	80	58	20	1,9	150	4,1	150	3,3	150	4,9
25-1"	90	60	23	2,1	160	5,1	160	4,7	160	6,3

* BW (butt weld) on request.

